



THE UNITED REPUBLIC OF TANZANIA
MINISTRY OF EDUCATION, SCIENCE AND TECHNOLOGY
NATIONAL EXAMINATIONS COUNCIL OF TANZANIA



**CANDIDATES' ITEMS RESPONSE ANALYSIS
REPORT ON THE CERTIFICATE OF SECONDARY
EDUCATION EXAMINATION (CSEE) 2022**

ARCHITECTURAL DRAUGHTING



**THE UNITED REPUBLIC OF TANZANIA
MINISTRY OF EDUCATION, SCIENCE AND TECHNOLOGY
NATIONAL EXAMINATIONS COUNCIL OF TANZANIA**



**CANDIDATES' ITEMS RESPONSE ANALYSIS
REPORT ON THE CERTIFICATE OF SECONDARY
EDUCATION EXAMINATION (CSEE) 2022**

072 ARCHITECTURAL DRAUGHTING

Published by
National Examinations Council of Tanzania,
P.O. Box 2624,
Dar es Salaam, Tanzania.

© **The National Examinations Council of Tanzania, 2023**

All rights reserved.

TABLE OF CONTENTS

FOREWORD.....	iv
1.0 INTRODUCTION.....	1
2.0 THE ANALYSIS OF THE CANDIDATES' RESPONSES IN EACH QUESTION.....	2
2.1 SECTION A: OBJECTIVE QUESTION.....	2
2.1.1 Question 1: Multiple Choice Items	2
2.2 SECTION B: SHORT ANSWER QUESTIONS	10
2.2.1 Question 2: Roofs.....	10
2.2.2 Question 3: Sections.....	14
2.2.3 Question 4: Instruments, Equipment and Materials	17
2.2.4 Question 5: Windows	20
2.2.5 Question 6: Water Supply	22
2.2.6 Question 7: Stairs and Staircase	25
2.2.7 Question 8: Residential House Planning.....	28
2.2.8 Question 9: Drainage System.....	30
2.2.9 Question 10: Doors.....	34
2.2.10 Question 11: Drainage System.....	36
2.3 SECTION C: STRUCTURED QUESTIONS.....	39
2.3.1 Question 12: Doors.....	39
2.3.2 Question 13: Roofs.....	44
3.0 ANALYSIS OF THE CANDIDATES' PERFORMANCE IN EACH TOPIC	48
4.0 CONCLUSION AND RECOMMENDATIONS.....	49
4.1 Conclusion.....	49
4.2 Recommendations	50
4.2.1 Recommendations to Students	50
4.2.2 Recommendations to Teachers.....	50
Appendix:	51

FOREWORD

This report presents Candidates' Items Response Analysis (CIRA) on Form Four National Examinations in Architectural Draughting subject which was conducted in November 2022. This report aims to provide feedback to all educational stakeholders on the factors that contributed to the candidates' performance in Architectural Draughting.

The Form Four National Examinations (CSEE) is a summative evaluation which intends to monitor students' learning and to provide feedback that teachers, students and other educational stakeholders can use to improve teaching and learning processes. This analysis justifies the candidates' performance in the Architectural Draughting subject. It reveals that candidates had good performance in the topic of Introduction to Building Architecture, Drawing Instruments and Equipment, Architectural Lettering, Architectural Scales, Residential House Planning, Sections, Fireplaces and Flues, Stairs and Staircases and Perspective Drawing. However, when it comes to the topic of Doors their performance was poor. Factors that affected the candidates' responses include inability of the candidates to identify the requirements of the questions, the misinterpretation of the question requirements and the improper application of knowledge and skills.

This report will help to identify candidates' strengths and weaknesses so as to improve learning before sitting for their Certificate of Secondary Education Examination (CSEE). It will help teachers to identify the challenging areas and take appropriate measures during teaching and learning process.

The National Examinations Council of Tanzania (NECTA) expects that the feedback provided in this report will give out the challenges which enable education stakeholders to take proper measures to improve teaching and learning of Architectural Draughting subject. Consequently, prospective candidates will acquire knowledge, skills and competence indicated in the syllabus for better performance in future examinations.

The Council appreciates the contribution of all those who participated to prepare this report.



Dr. Said A. Mohamed
EXECUTIVE SECRETARY

1.0 INTRODUCTION

This report provides a detailed analysis of the performance of candidates who sat for the Certificate of Secondary Education Examination (CSEE) in Architectural Draughting subject. The examination paper was set according to the examination format which was developed from the Civil Engineering Syllabus for Secondary School Education issued in 1994.

The examination paper had thirteen (13) questions categorised into three sections namely A, B, and C. Section A consisted of one (1) objective question with ten (10) multiple-choice items, weighing one (1) mark each. Section B had ten (10) short answer questions, each carrying six (6) marks. All questions in sections A and B were compulsory. Section C had two (2) optional structured questions, each weighing 30 marks. Candidates were required to answer one (1) question from this section.

A total of 328 candidates sat for Architectural Draughting subject in 2022. Among them, only 108 (32.92%) candidates scored the credit pass grades B and C. The statistical analysis shows that 159 (48.48%) passed with grade D, while 61 (18.60%) candidates failed by scoring grade F. This implies that the general performance in this subject was good. However, when the results are compared with those of 2021, a decrease of 3.31 per cent was observed. In 2021 the number of candidates who passed was 288 (84.71%).

Figure 1 shows the general distribution of scores and candidates' performance in the 2022 examination.

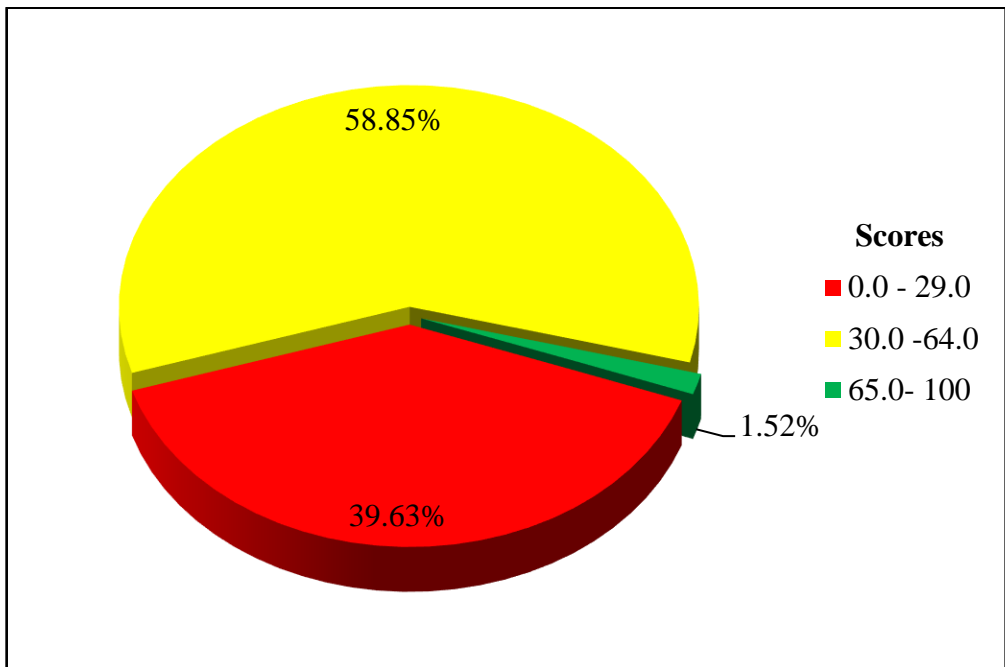

Figure 1: *The Candidates' Performance in 2022*

This report analyses candidates' responses with regard to the requirements of questions. In the course of analysis, a brief notes are provided on what candidates were required to do and the reasons for the levels of their performance. Samples of candidates' good and poor responses are also inserted in the form of extracts to illustrate the cases presented. Charts are also used to summarize candidates' performance in particular questions. The candidates' performance has been categorized into three groups: good, average and poor. The categories with the ranges of 65–100, 30–64 and 0–29, respectively. Green, yellow and red colours represent the three categories of the performance. Finally, the report presents a conclusion and recommendations for implementation.

2.0 THE ANALYSIS OF THE CANDIDATES' RESPONSES IN EACH QUESTION

2.1 SECTION A: OBJECTIVE QUESTION

2.1.1 Question 1: Multiple Choice Items

This question had ten (10) multiple choice items from (i) to (x). It required candidates to choose the correct answer from among the five

(5) given alternatives (A to E) and write the letter of the correct answer in the answer booklet provided. The items were constructed from ten (10) topics, namely *Introduction to Building Architecture, Drawing Instruments and Equipment, Architectural Lettering, Architectural Scales, Residential House Planning, Sections, Windows, Fireplaces and Flues, Water Supply and Perspective Drawing.*

All 328 (100%) registered candidates attempted the question, of whom 28 (8.54%) candidates scored from 0 to 2 marks. The candidates who scored from 3 to 6 marks were 261 (79.57%), whereas 39 (11.89%) candidates scored from 7 to 10 marks. The performance of the candidates in this question is summarized in Figure 2.

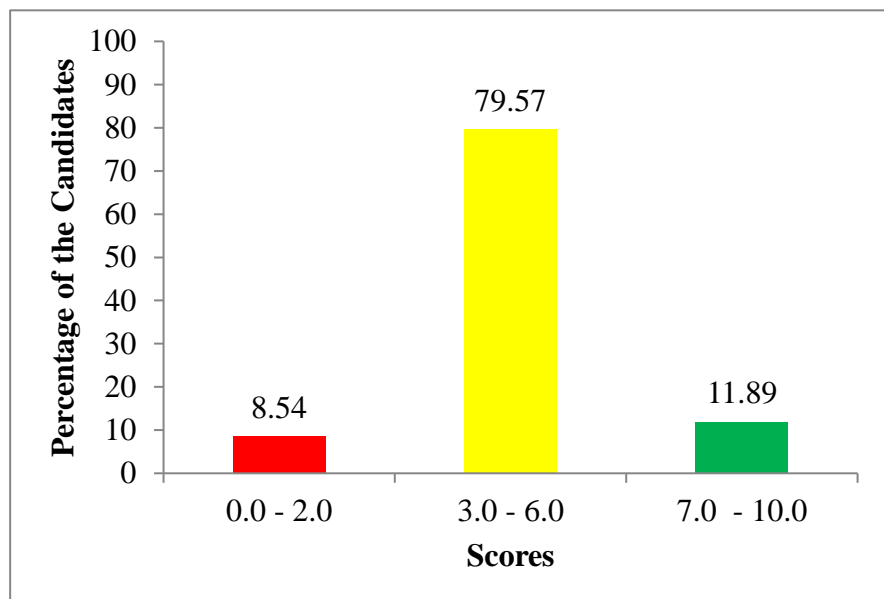

Figure 2: *The Candidates' Performance in Question 1*

Figure 2 shows that the candidates' performance in this question was good, as 91.46 percent of the candidates scored average marks and above. The candidates who performed well in the question demonstrated a strong ability of applying knowledge of various topics to identify the correct answers among the given alternatives. The candidates attempted all items although not all of them were answered correctly. The items in which most candidates failed were item (vii) from the topic of *Perspective Drawing* and item (ix) from the topic of

Water Supply. The analysis of the candidates' responses also reveals that the majority of the candidates correctly selected item (ii) from the topic of *Introduction to Building Architectural*, item (v) from the topic of *Drawing Instruments and Equipment*, and item (viii) from the topic of *Architectural Lettering*. The performance in the rest of the items was performed average.

The strengths and weaknesses of the candidates in choosing the correct answers in individual items are analysed as follows:

Item (i) was set from the topic of *Window*. It tested candidates' ability to identify the type of windows used in a house. The question was:

Which type of window will you use to a house having an enclosed space below the roof, which requires air and light?

A *Dormer window* B *Corner window* C *Bay window*
D *Skylight window* E *Clerestorey window*

The correct answer was A, '*dormer window*'. Candidates who chose this alternative had enough knowledge on the types of window and their functions. Candidates who selected the incorrect responses failed to recall different locations and shapes of windows for special functions. For instance, alternative B, '*corner window*' is located at the corner of a room to ensure that light and ventilation are obtained in two directions at the right angle. Alternative C, '*bay window*' was also an incorrect response, because this kind of window is projected outside on the external wall of the room. The projection may be triangular, circular, rectangular, or polygonal in the plan introduced to increase the area of the opening for admittance of light and air.

Moreover, candidates who choose alternative D, '*skylight window*' did not realize that this is a fixed window provided on the sloping surface of a pitched roof. It is differentiated from a dormer window because it is parallel to the sloping surface of a pitched roof and allows the room below to receive only natural light. The last alternative E, '*clerestory window*' was also an incorrect response. A clerestory window is used to achieve better ventilation and cooling in the living room or the main

room of a building with a ceiling height greater than the surrounding rooms.

Item (ii) was developed from the topic of *Introduction to Building Architecture*. It tested the candidates' ability to identify duties of building team member. The question was as follows:

Who is responsible to prepare a site plan drawing of a building?

- A A surveyor B Town engineer C Town planner
D An architect E A land officer

The correct response from among the alternatives, was D, '*an architect*' who is a member of a building team responsible for preparing working drawings of building to be constructed in a particular area. Candidates who chose this alternative had knowledge of the duties of an architect. Candidates who chose alternative A, '*a surveyor*', were not well versed with the duties of members of a building team, because in practice a surveyor is either dealing with building quantities or determining the boundaries and elevations of the land or structures. A surveyor is not concerned with the preparation of plan views. Alternatives B, '*town engineer*' and C, '*town planner*' are responsible for the supervising construction projects and planning towns respectively. Both of the alternatives were incorrect. Alternative E, '*land officer*' is an officer responsible for building permits and preventing boundary conflicts among people. Hence, this alternative was also incorrect.

Item (iii) was set from the topic of *Residential House Planning*. The item was designed to assess candidate's knowledge of various sets of working drawings. The question was as follows:

A client decided to use architectural drawings to select one among proposed residential house with different size and arrangement of rooms. Which type of drawing a client would use?

- A Elevation drawing B Floor plan drawings C Roof plan drawing
D Site plan drawing E Sectional view drawings

The correct response was B, '*floor plan drawings*,' which shows the size, position and arrangement of walls, windows, doors and partitions

in a residential house. Candidates who chose this response had knowledge and practical skills needed in developing the floor plan of a building.

Alternatives A, C, D, and E were incorrect. Alternative A, '*elevation drawings*' shows the finished appearance of a given side of a house and the vertical height dimension of doors, windows and the verandah. Alternative C, '*roof plan drawing*' shows the plan of trusses, rafters, purlins, sheets and types of roof to use in a building. However alternatives D, '*site plan drawings*' and E, '*sectional view drawings*' were incorrect responses, since they are the plans which show the relationship between a building and the site boundaries and adjoining roads and buildings. They also showed the depth of the foundation, walls, plinth and roof, respectively.

Item (iv) was extracted from the topic of *Fireplaces and Flues*. It required the candidates' to choose item that describes the projecting brickwork containing the fire and supports the chimney breast over the fireplace. The question was as follows:

Which of the following terms describe the projecting brickwork, which contain the fire and support chimneybreast over the fireplace?

- | | | |
|-------------|---------|----------|
| A Fire back | B Flue | C Hearth |
| D Lintel | E Jambs | |

The correct response was E, '*jamb*'. Candidates who chose this response were knowledgeable of the fireplace settings. They knew that a jamb is a projecting brickwork containing fire and supports chimney breast over the fireplace. Response A, '*fire back*' was incorrect because a fire back is a shaped unit or laid masonry of refractory brick forming the fire place's rear and side walls.

Candidates who opted for response B, '*flue*' were also wrong because a flue is a vertical pipe or duct removing smoke, combustion gases and other gaseous products from the fireplace to outside of the building. Moreover, candidates who chose response C, '*hearth*' were not aware that a hearth is the base or the floor of the fireplace. The last option D, '*lintel*' was an incorrect answer because the fireplace lintel is a bar or a

beam placed horizontally across the top of the fireplace opening. The purpose of the fireplace lintel is to spread the load from the opening of the fireplace across the firebox.

Item (v) was set from the topic of *Drawing Instruments and Equipment*. It tested the candidates' ability to identify the grade of a pencil. The question was:

Which of the following is the softest pencil to be used for drafting purpose?

- A HB B 1B C 2B
D H E 2H

The correct alternative was C, '2B', the candidates who chose this alternative were knowledgeable of the grades of pencils coded by figures and letters. The letters HB denotes the medium grade. The increase in the hardness is shown by the value of the figure put in front of the letter H. That is, the grade becomes softer as the figure placed in front of the letter B increases. Other distractors included B, '1B', which is soft but not as soft as '2B' and A, 'HB', which denotes a medium pencil. Moreover, distractors D, 'H' and E, '2H' represent pencils with hard leads.

Item (vi) was extracted from the topic of *Architectural Scales*. It tested candidates knowledge of identifying types of scale used in architectural drawings. The question was:

What type of scale is used when a drawing is smaller than the actual size of the object?

- A Enlarging scale B Reducing scale C Small scale
D Decreasing scale E Increasing scale

The correct response among, the given alternatives, was B, '*reducing scale*'. In this case, the scale factor is small hence the actual size of the object is greater than the drawing. Candidates who opted for alternative B were able to use their knowledge of architectural scale to interpret the question and select the correct response. Candidates who chose alternative A, '*enlarging scale*' were wrong because the scale factor of this scale is large, thus the drawing size is larger than the actual size.

Candidates who chose alternatives C, ‘*small scale*’, D, ‘*decreasing scale*’ and E, ‘*increasing scale*’ were not conversant with the types of scale used in architectural draughting because those alternatives are not among the types of architectural scale.

Item (vii) was set from the topic of *Perspective Drawing*. Candidates were required to apply their knowledge on perspective drawing to identify the location of a vanishing point. The question was:

Suppose you are drawing a one-point perspective. Where will you locate the vanishing point?

- A *Above the horizon* B *At picture plane* C *On the horizon*
D *At station point* E *At ground line*

The correct alternative was D, ‘*horizon line*’. Such candidates’ demonstrated the proficiency in practical perspective drawing skills, specifically in the procedures for developing a one-point perspective view. Candidates who chose A ‘*above the horizon*’ were not aware that a vanishing point is only located on the horizon in one or two-point perspective view. Candidates who chose alternative B, ‘*picture plane*’, D, ‘*at station point*’ and E, ‘*at ground line*’ were not familiar with terms used in two-point perspective drawings.

Item (viii) was extracted on the topic of *Architectural Lettering*. It tested practical knowledge of forming letters in architectural drawing. The question was:

Lettering is used to give descriptive words and notice in order to produce drawings, which are clearly understood. What does the single stroke-lettering mean?

- A *Cursive writing*
B *Uniformity in letter as obtained in one stroke of the pencil*
C *Writing in one stroke without lifting the pencil*
D *Writing only with hand and with small diameter lead pencil*
E *Cutting plane name*

The correct response from among the given alternatives was B, ‘*uniformity in a letter as obtained in one stroke of the pencil*’. Alternatives A, ‘*cursive writing*’ C, ‘*writing in one stroke without*

lifting the pencil and D, *writing only with hand and with small diameter lead pencil* denote writing skills of architectural lettering. Candidates who chose any of these choices lacked knowledge and practical skills in architectural lettering. Candidates in this category confused between the architect lettering and the style of writing (writing skills).

Item (ix) was set from the topic of Water Supply. It required candidates to identify plumbing fittings in the indirect water supply system. The question was:

Suppose you are working with local water authority and asked to connect an indirect water supply system in a residential building: which plumbing fitting will you connect directly?

- A Sink B Bath tube C Shower
 D Wash basin E Water closet

The correct response was A, *'Sink'*. On an indirect supply system, cold water is supplied to all outlets from a water storage cistern except for the cold water supply to the sink(s), where the drinking water tap is connected directly to the incoming supply from the main owned by the local water authority. Candidates who opted for alternatives B, *'bath tub'*, C, *'shower'*, D, *'wash basin'* and E, *'water closet'* did not form any particular pattern. Such candidates were not conversant with the type of water supply systems. As a result they made their choices by guessing.

Item (x) was developed from the topic of *Sections*. It tested candidates' knowledge on section drawing of a building. The question was:

The figure below shows one among the methods of labeling section lines. What does letter A represents?

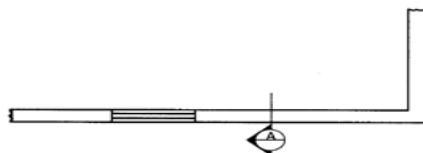

- A *Extended section* B *Sheet of section reference line*
 C *Section line name* D *Cutting line name*
 E *Cutting plane name*

The correct answer was C, '*Section line name*'. Candidates who chose the correct response were aware the section marker circle upper part letter or number refers to section line name or number. Candidates who chose other options were not correct because option B, *sheet of section reference line* are shown on the lower part of section marker circle. The candidate who choose alternative A, *Extended section*, D, *Cutting line name* and E, *Cutting plane name* were not aware that, those alternatives does not form part of a section line.

2.2 SECTION B: SHORT ANSWER QUESTIONS

This section consisted of ten (10) short answer questions; each question weighed six (6) marks. The score ranges used for grading the performance of candidates in each question in this section are indicated in Table 1.

Table 1: Score Ranges for Grading Candidates' Performance in Questions 2 to 11

Scores Range (s)	General Performance
0 – 1.5	Weak
2- 3.5	Average
4 - 6	Good

2.2.1 Question 2: Roofs

The question had parts (a) and (b). Candidates were required to distinguish the given forms of roofs; in part (a) gambrel and mansard roofs; and part (b) gable and hip roofs. The question tested candidates' ability to differentiate different forms of roof based on number of break and slope direction.

The analysis shows that 328 (100%) candidates attempted the question, of which 204 (62.20%) candidates scored from 0 to 1.5 marks. Candidates who scored from 2 to 3.5 marks were 75 (22.87%) while 49 (14.93%) candidates scored from 4 to 6 marks. The analysis shows that 23 (7%) candidates scored full marks. Figure 3 summarizes the candidates' performance in Question 2.

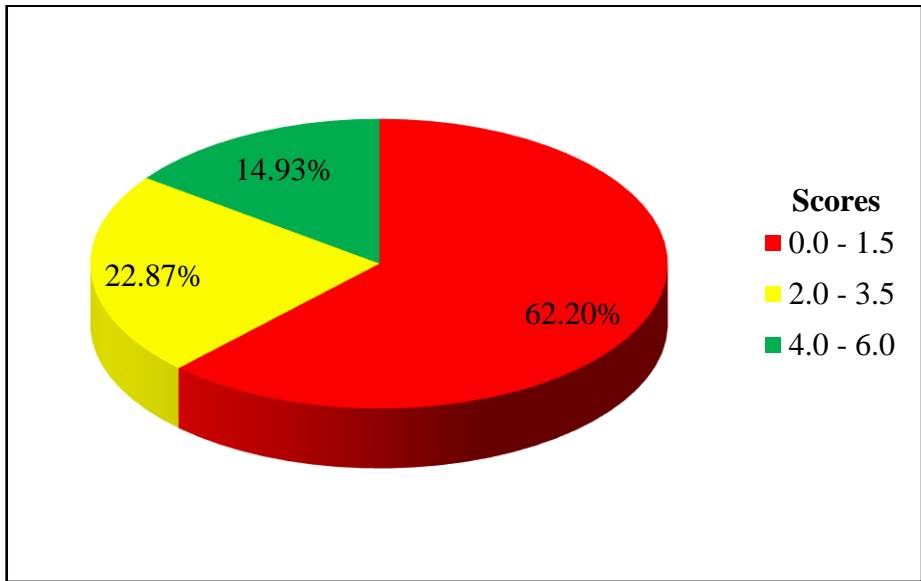

Figure 3: *The Candidates' Performance in Question 2*

Figure 3 indicates that the general performance of candidates in this question was average, as 37.80 percent of the candidates scored average marks and above. The analysis shows that candidates who scored average marks were able to respond to the question in both parts (a) and (b), but only managed to distinguish the type of roof with sketches without giving an explanation. Further analysis reveals that candidates who scored from 4 to 6 marks had sufficient knowledge of roof forms. These candidates scored high marks of differentiating roofs based on the number of breaks and slope direction. Such candidates were knowledgeable and skilled in various types of roofs. Extract 2.1 shows a sample of correct responses provided by one of the candidates.

02. @

Gambrel roof - Is a type of roof where by it is like a pitched roof but its slopes are broken at a certain points and it slopes in only two directions
White

Mansard roof - Is a type of roof which is a hip roof and its slopes are broken at a certain point and it slopes in both four directions

Sketch

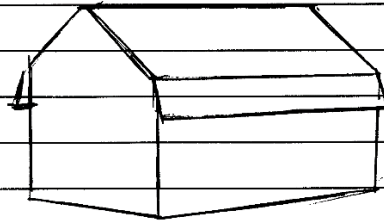

Gambrel roof

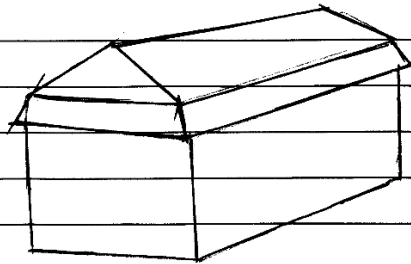

Mansard roof

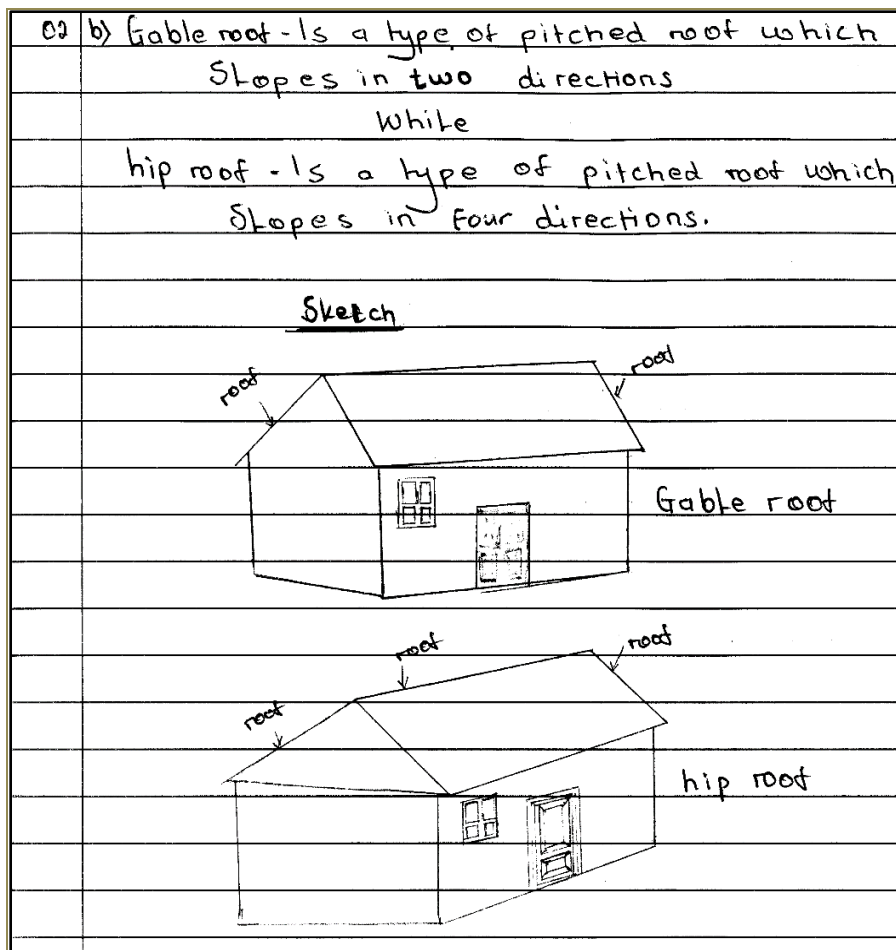

Extract 2.1: A sample of correct responses to Question 2

Extract 2.1 shows a sample of responses from a candidate who managed to provide relevant differences between the gambrel roof and mansard roof in part (a), and the gable and hip roofs in part (b).

Further analysis reveals that 62.2 percent of the candidates performed poorly by attaining the score range of 0 to 1.5 marks. Such candidates failed to distinguish correctly with neither explanations nor sketches as required by the question. Moreover, some candidates were not able to interpret the question. Some responded conversely between gable and gambrel, hip and mansard while others wrote meaningless sentences. Some drawings were not neat and had incorrect labeling, especially, the hipped roof. This implies that drafting techniques were among the challenges facing candidates in this category. Many of the candidates

who scored a 0 mark decided to write anything concerning roofs, regardless of the requirements of the question. This was attributed by insufficiency knowledge and skills in forming roofs. This is justified by a response from one of the candidates, as shown in Extract 2.2.

2a)	Gambrel roof is the roof which consist of the closed eave.
	WHILE
	Mansard roof is a combination of king and queen post truss.
2b)	Gable roof is the roof which consist open eave. Extended board board called fascia board. (Covered four sides)
	WHILE
	Hip roof is a roof which doesn't have a fascia board. (Covered two opposite sides).

Extract 2.2: A sample of incorrect responses to Question 2

Extract 2.2 shows a sample of responses from one of the candidates who applied irrelevant roof terms in differentiating between roof types, resulting to zero marks.

2.2.2 Question 3: Sections

The question comprised of two parts (a) and (b). In part (a), candidates were required to identify three factors that affect the choice of scale to be used for drawing a section of a building. In part (b), candidates were required to distinguish between a cross section and a longitudinal section of the house floor plan. The question tested candidates' practical skills of drawing a section of a building.

The analysis shows that 328 (100%) candidates attempted the question, of whom, 176 (53.66%) candidates scored from 0 to 1.5 marks. The candidates who scored from 2 to 3.5 marks were 134 (40.85%), whereas 18 (5.49%) candidates scored from 4 to 6 marks. Figure 4 shows the performance of the candidates in this question.

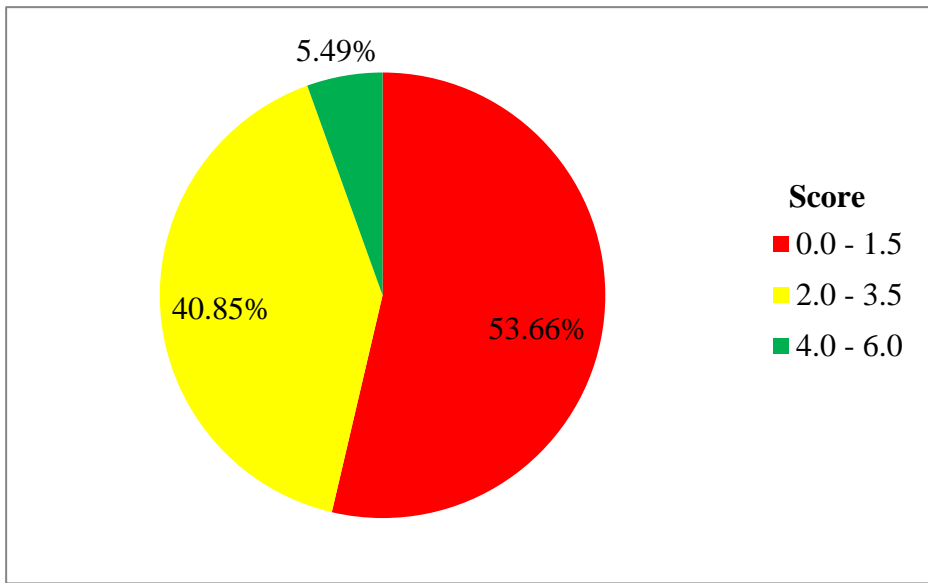

Figure 4: *The Candidates' Performance in Question 3*

Generally, the performance of candidates in this question was average, as 46.34 percent of candidates scored average and above marks. Such candidates had good practical skills in drawing a section of a building. The majority of the candidates, in part (a) could name at least two factors that influence the scale used to draw a section of a building, such as the size of the drawing, the size of the project to be drawn, the placement of the section, the purpose of the section, and the size of the drawing sheet.

In part (b), some candidates were able to describe the details shown in a section drawing but failed to identify where the axis of cutting on the floor plan drawing would be. A cross section is a section where the cutting plane is parallel to the short axis of the structure, while a longitudinal section is the type of section produced when the cutting plane is parallel to the long axis of the structure. Extract 3.1 presents a sample of the correct response in this question.

3	① factor affect the choice of scale.
	i/ <u>Characteristic of the drawing</u>
	» Some of the drawing contain many detail which its hard to express in a certain type of scale.
	ii/ <u>Size of drawing sheet.</u>
	» Some of the drawing they drawing in a large scale but sheet is small so they be drawn on the sheet.
	iii/ <u>Detail to be shown</u>
	» Some of the detail is its hard to be shown in a small scale so suppose to be drawn in large scale.
3	② <u>Cross section</u> is the section which cutting line pass horizontally of the drawing so that to show horizontal ^{internal} profile of the object
	While.
	<u>Longitudinal section</u> is the section where by cutting line pass vertically to the drawing so that to show the vertical ^{pre internal} profile of the object.

Extract 3.1: A sample of correct responses to Question 3

Extract 3.1 shows a sample of responses from one of the candidates who managed to identify factors that affect the choice of a scale to be used for drawing sections of the building in part (a) and partially distinguish between a cross section from a longitudinal section of a house floor plan in part (b), of the question.

Further analysis reveals that 53.66 percent of the candidates performed poorly, after attaining scores ranging from 0 to 1.5 marks. Such candidates failed to list at least two factors affecting the choice of a scale for drawing a section of a building in part (a). They totally failed to distinguish between a cross section and a longitudinal section of the

house floor plan. Candidates who scored 0 avoided to write anything, afraid to provide irrelevant responses. Some candidates just skipped the question. This is an indication that candidates in this category lacked knowledge on technologies of producing section drawings. Extract 3.2 provides a sample of incorrect responses by a candidate in this category.

	order to the drawing to fit on the drawing paper.
	ii) Size of the material used
	The material used should be considered with their size in order for scale also used to be easy for drawing.
	iii) Skills of a person drawing a section.
	Also the skills should be considered because there are some people who are very good for the certain scale than other scale.
	b) To distinguish between.
	Cross section and longitudinal section.
	Longitudinal section is the section which is drawn to show the vertically structure of the structure while cross section is the section which show the horizontally part of the structure.

Extract 3.2: A sample of incorrect responses to Question 3

Extract 3.2 shows a sample of responses from one of the candidates who wrongly used the height of the structure to distinguish between a cross and longitudinal part of the structure.

2.2.3 Question 4: Instruments, Equipment and Materials

In this question, candidates were required to explain how to keep drawings clean while protecting the surface of the paper. The question tested candidates' skills of preparing a pencil drawing.

The question was attempted by 328 (100%) candidates whose scores were as follows: 78 (23.78%) candidates performed poorly as they scored from 0 to 1.5 marks; 102 (31.10%) candidates scored averagely from 2 to 3.5 marks and 148 (45.12%) candidates had good performance after scoring from 4 to 6 marks. Figure 5 summarizes the overall performance in the question.

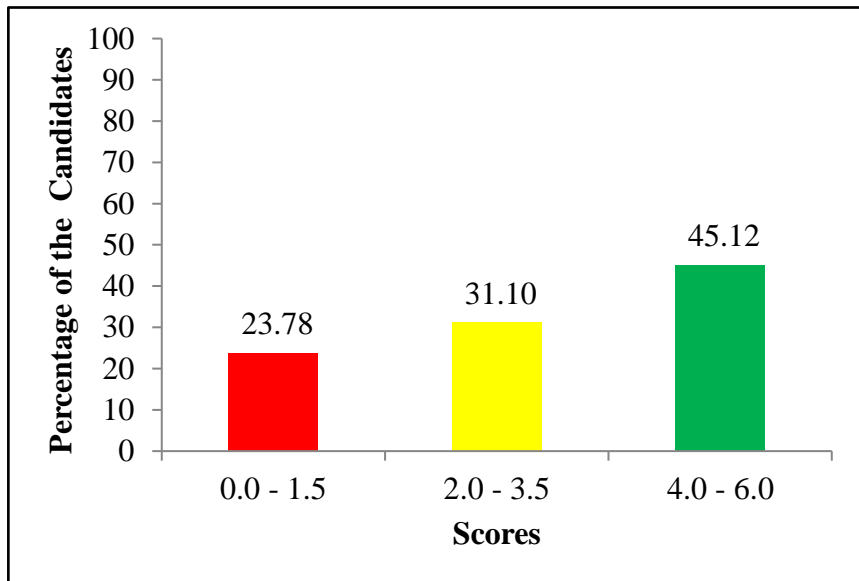

Figure 5: *The Candidates' Performance in Question 4*

Figure 5 shows that 76.22 percent of the candidates scored 2 marks and above, which is an indicator of a good performance. Such candidates were relatively able to enumerate precautions to observe to keep a drawing clean and preserve the surface of the drawing paper. Their scores depended on the number of the correct responses they provided. Candidates were supposed to write down important points for the drawing to be clean. These include using clean equipment and instruments and good pencils; keeping hands clean and touching the paper with their fingers as little as possible, keeping sharpening pencils away from the drawing board and table, avoiding unnecessary rubbing of the surface of the drawing board with T- square and set square; making any easements carefully and removing all crumbs by blowing or lightly flicking with a clean handkerchief or hand. If a drawing

should be done on several small areas of the sheet, covering the unrequired part with a tracing or detail paper is necessary. Extract 4.1 is an illustration of the correct responses from one of the candidates.

4)	Washing and drying my hands.
i)	Clearing the table with a clean cloth.
ii)	Properly sharpening the pencil.
iii)	Using a clean eraser.
iv)	Avoid unnecessary erasing of lines.
v)	Avoid touching the pencil lead and properly erasing of unwanted lines.

Extract 4.1: A sample of correct responses to Question 4

Extract 4.1 shows a sample of responses from one of the candidates who correctly enumerated precautions to observe in order to keep a drawing clean and preserve the surface of the drawing paper.

However, 23.78 per cent of the candidates scored low marks, from 0 to 1.5. The analysis shows that candidates who scored such low marks only wrote one correct point on keeping a drawing clean. Candidates who scored 0 either wrote illogical and irrelevant answers or skipped the questions altogether. Responses given by candidates in this category indicate that they lacked practical knowledge and skills in preparing the pencil drawing. This is revealed by a response from one of the candidates, as shown in Extract 4.2.

4)	(i) Setting a drawing sheet on a table or drawing box
	(ii) Setting set square and T-square
	(iii) Draw a boarder line
	(iv) Draw a title block
	(v) Start to prepare the drawing
	(vi) Redraw the lines and rough drawing

Extract 4.2: A sample of incorrect responses to Question 4

Extract 4.2 shows a sample of the incorrect responses from a candidate who presented steps to follow when drawing instead of explaining how to produce clean and neat architectural drawings.

2.2.4 Question 5: Windows

This question had parts (a) and (b). In part (a), candidates were required to explain, (i) why someone should opt for a fan light, and (ii) where the fan light is placed in a building. In part (b), the candidates were required to explain the purpose of providing architraves as the window frame finishes. The question tested the candidates' knowledge on the types and parts of a window.

A total of 328 (100%) candidates attempted the question, of which 259 (78.96%) candidates scored from 0 to 1.5 marks. Candidates who scored from 2 to 3.5 marks were 53 (16.16%), whereas 16 (4.88%) scored from 4 to 6 marks. The performance of the candidates in this question is summarized in Figure 6.

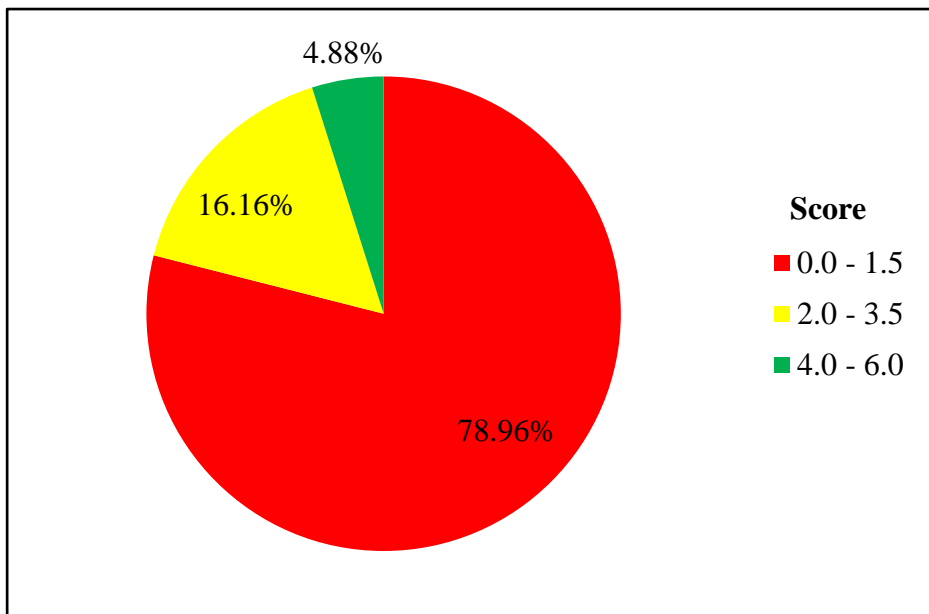

Figure 6: *The Candidates' Performance in Question 5*

The general performance of candidates in this question was poor as depicted in Figure 6. The majority of the candidates (78.96 %) scored

low marks because they could not clearly identify parts of the door and window frame. They failed to recall that a fan light is fitted in between the head of the doorframe and the transom which was the requirement in part (a) (ii). This response could have enabled them to remember the use of the fan light in part (a) (i). In part (b), the majority of the candidates failed to explain the purpose of providing architraves as window frame finishes.

Candidates who scored 0 failed to attempt both parts of the question. The majority of such candidates in answering part (a) of the question, explained how an electrical fan is used to create a flow of air. They also explained the architrave by describing other parts of the window frame and shutter. There are a number of factors, which contributed to the failure of the candidates in this question. These factors include poor understanding of the subject matter and wrong interpretation of the question. Extract 5.1 illustrates a sample of the incorrect responses by the candidate who failed the question.

5.	(a) For proper lighting in the building.
	(ii) Its placed on the walls or at the roof centre.
	(b) i) For attraction / decoration.
	ii) Its durable and strong.

Extract 5.1: A sample of incorrect responses to Question 5

Extract 5.1 shows responses by a candidate who misinterpreted the question by explaining a fan light as an electrical fan used to create a flow of air in a room in part (a) (i). He/she also write the function requirement of an architrave instead of its uses in part (b).

Furthermore, candidates with scores ranging from 2 to 6 marks correctly managed to (i) explain why someone would choose a fan light and (ii) explain where the fan light is located in a building. In part (b), the candidates partially explained the purpose of providing architrave as a finishing to the window frame. Extract 5.2 is a sample of the correct responses from one of the candidates in this category.

5.	(a) i/. Fan light helps/allows light to enter the building. Also it helps for some amount of air to enter the room.
	ii/. Fan light is ^{an opening which is} placed at the top or upper part of the door frame.

Extract 5.2: A sample of correct responses to Question 5

Extract 5.2 is a sample of responses from one of the candidates who in part (a) managed to explain a reason for someone to opt for a fan light and its location in a building.

2.2.5 Question 6: Water Supply

The question required candidates to identify pipes labeled (i) – (vi) in the figure provided below.

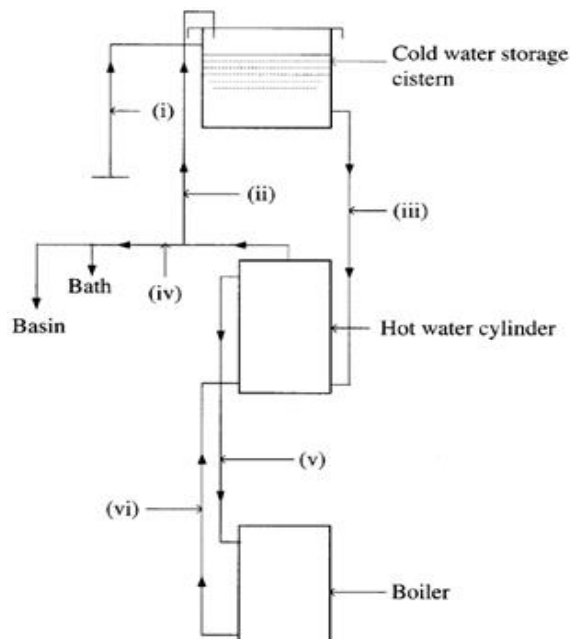

The analysis shows that 328 (100%) candidates attempted the question. Out of which, 277 (84.45%) scored from 0 to 1.5 marks. Candidates who scored from 2 to 3.5 marks were 45 (13.72%), while 6 (1.83%) candidates scored from 4 to 6 marks. Only 1 (0.3%) candidate scored 6

marks in the question. Figure 7 summarizes the candidates' performance in this question.

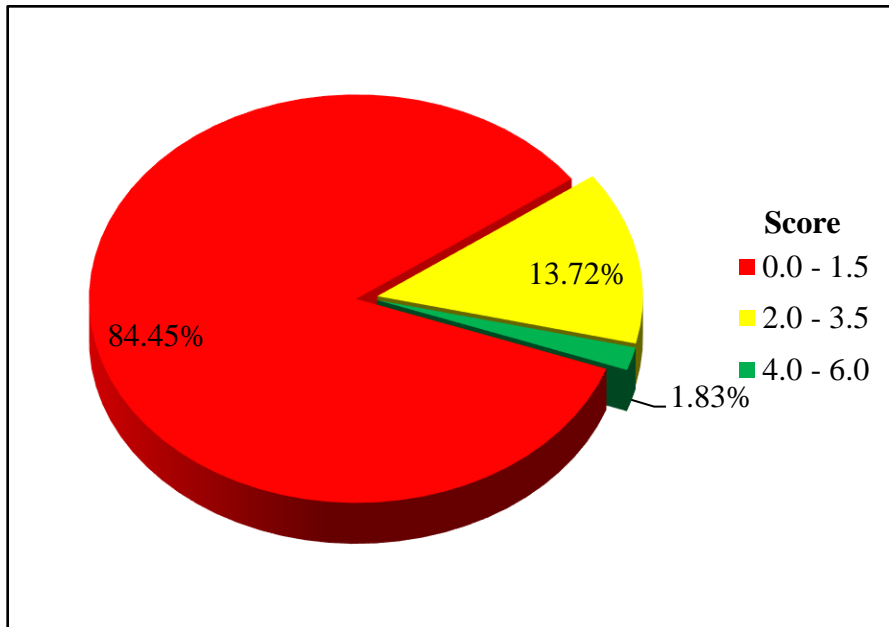

Figure 7: *The Candidates' Performance in Question 6*

Generally, the performance of candidates was poor because 84.45 percent of all the candidates were not able to score above average. The candidates scored low marks because of their inadequate knowledge of hot water supply systems which could at least enable them to identify two pipes used in the direct hot water supply system.

Further analysis shows that candidates who scored 0 provided irrelevant answers that were completely out of context. Such meaningless responses are indicators that the candidates were not conversant with the operation of water supply systems. If they had covered the topic well, they could identify the indirect hot water supply pipes as (i) service pipe or rising main, (ii) open vent or expansion pipe; (iii) cold feed pipe; (iv) hot water supply pipe; (v) primary flow pipe and (vi) primary return pipe. Extract 6.1 is a sample of the incorrect responses provided by the candidates.

6.1)	UNHEATED PIPE,
ii)	rubric pipe
iii)	concrete pipe
iv)	Plastic pipe
v)	soil pipe
vi)	VENT PIPE

Extract 6.1: A sample of incorrect responses to Question 6

Extract 6.1 is a sample of responses from a candidate who wrote the types of pipes based to make up materials instead of the direct hot water supply pipes.

However, the candidate who scored 2 marks or above managed to identify the direct hot water system pipes. The variation in their marks was because some candidates provided repetitive answers. For instance, where the answer was primary flow, others wrote flow pipes. Such candidates had insufficient knowledge of water supply systems. Nevertheless, 1.83 percent identified the hot water supply system pipes. This is an indicator that candidates in this category had enough knowledge of the topic of Water Supply, as seen in Extract 6.2.

6	i) Service pipe
	ii) Ventilation pipe
	iii) Cold water pipe
	iv) Distribution pipe
	v) Primary flow pipe.
	vi) Primary return pipe

Extract 6.2: A sample of correct responses to Question 6

Extract 6.2 is a sample of responses from one of the candidates who was able to identify the hot water supply system pipes labeled (i) – (vi). Hence, he/she scored full marks.

2.2.6 Question 7: Stairs and Staircase

The question tested ability of the candidates' to locate a landing of different types of stairs. Candidates were required, with the aid of plan sketches, to explain how the landing of the following types of stairs is proposed (a) bifurcated stair and (b) quarter turn stair.

The question was attempted by 328 (100%) candidates, of whom 58 (17.68%) candidates scored from 0 to 1.5 marks. Further data analysis indicates that 51 (15.55%) candidates scored from 2 to 3.5 marks, while 219 (66.77%) candidates scored from 4 to 6 marks. Figure 8 illustrates the candidates' performance in this question.

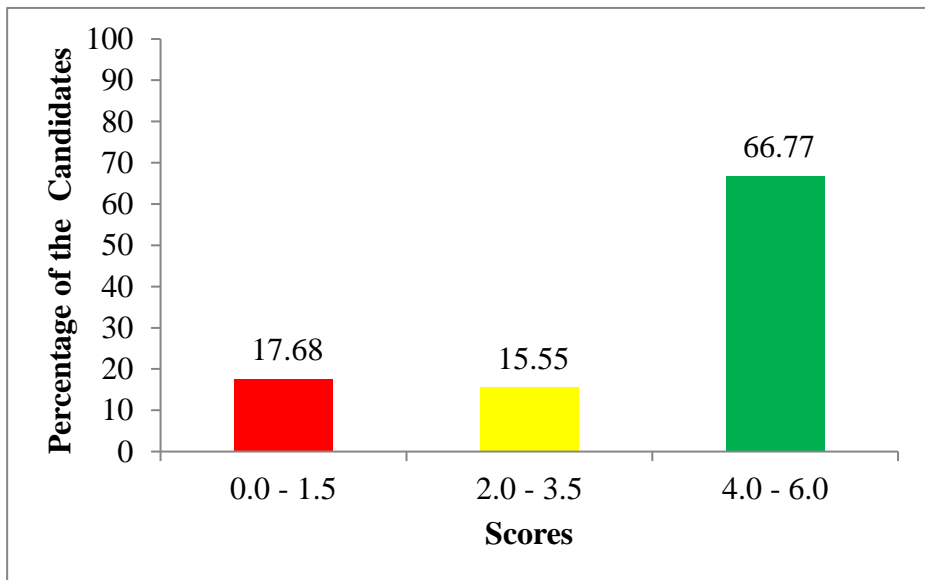
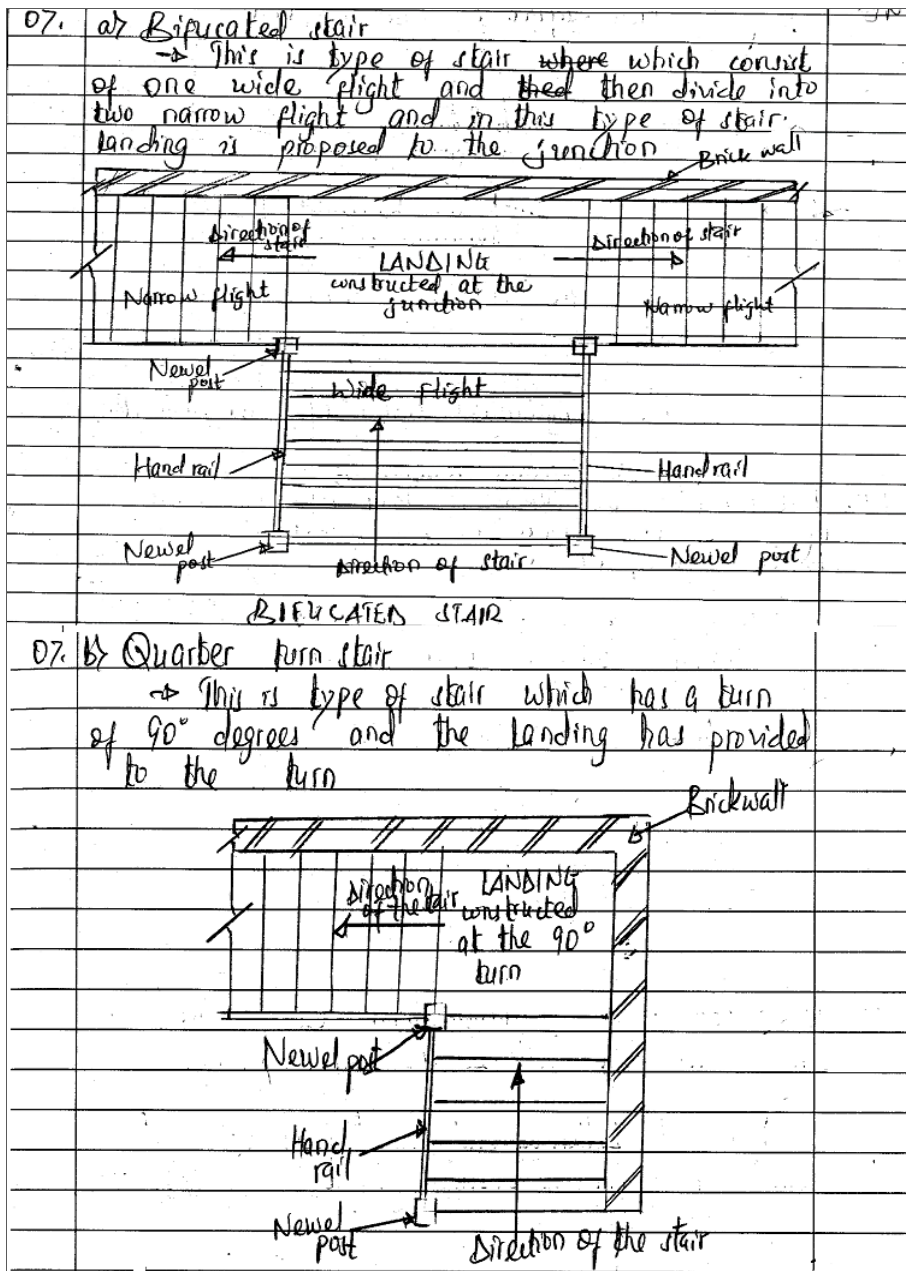

Figure 8: *The Candidates' Performance in Question 7*

Figure 8 illustrates that the general performance of the candidates in this question was good, as 82.32 per cent of the candidates scored 2 marks and above. Candidates who scored higher marks 4 to 6 marks managed to correctly draw the bifurcated and quarter turn stair landings. Nevertheless, the majority of the candidates failed to give the correct explanations of stairs, except for those who scored 6 marks. On the other hand, some candidates were able to draw the types of stairs but failed to explain about the other type of stair, hence scored average

marks. Extract 7.1 presents a sample of the correct responses to Question 7.



Extract 7.1: A sample of correct responses to Question 7

Extract 7.1 shows a response from one of the candidates who managed to draw and explain how the landing bifurcated stair and quarter turn stair are proposed.

Furthermore, candidates who scored low marks (0 - 1.5) were only able either to draw or explain one of the stairs. The majority of the candidates who scored 0 mark lacked knowledge of stairs and staircases as well as the failure to comprehend to the question. For example, some of the candidates failed to differentiate between a section drawing and a plan drawing as asked in the question. Such candidates ended up drawing sections of different types of stairs. Extract 7.2 presents a sample of such incorrect responses.

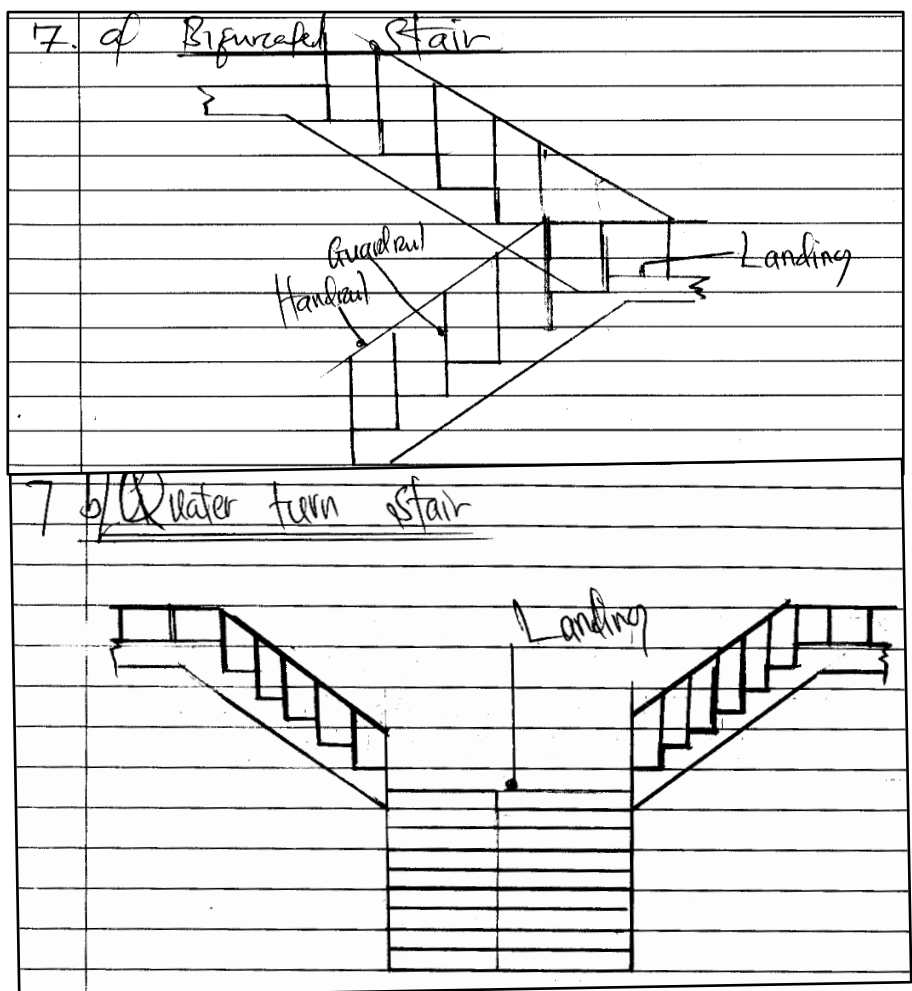

Extract 7.2: A sample of incorrect responses to Question 7

Extract 7.2 shows a response from one of the candidates who failed to comprehend the question and hence drew a sections of a dogleg and bifurcated stairs and which were given a wrong title.

2.2.7 Question 8: Residential House Planning

The question tested the candidates' ability to recall necessary information required for designing a residential house. The candidates were asked to identify six pieces of information they would need from the client during the house planning process.

The analysis shows that 328 (100%) candidates attempted the question, of whom 105 (32.01%) scored from 0 to 1.5 marks. Further analysis indicates that 150 (45.73%) candidates scored from 2 to 3.5 marks, while 73 (22.26%) candidates scored from 4 to 6 marks. Figure 9 presents the candidates' performance in this question.

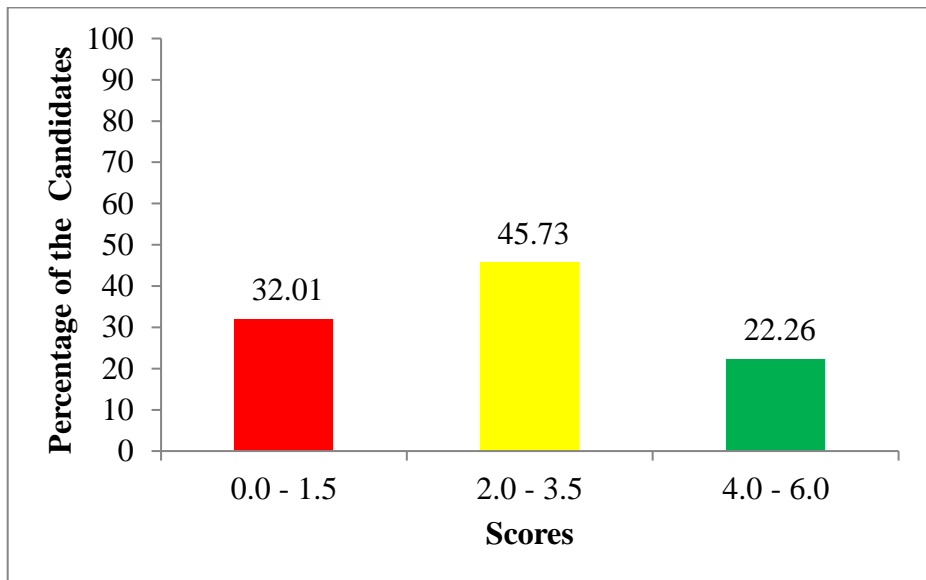

Figure 9: *The Candidates' Performance in Question 8*

Figure 9 shows that 67.99 percent of the candidates scored 2 marks and above, which indicates a good performance. The candidates scored high marks because of sufficient knowledge of the subject matter and the ability to recall the necessary information needed before planning a residential house. Such candidates were able to identify the essential

information they would need from the client, during the planning of the house. Their scores depended on the number of the correct responses each provided. Candidates were supposed to list the steps to follow when preparing the preliminary sketches such as the financial ability and the budget of the client; needs of the client in terms of functional spaces; minimum requirements of the client; the client's preference in architectural style; the size of the site; the location of the site; the number of occupants; and the topographical features of the site. Extract 8.1 is an illustration of the correct responses from one of the candidates.

8	Factors to consider when designing a residential house.
(i)	Type of the building. It help an architect to know the need of the building.
(ii)	Numbers of rooms. it help to identify the size of the building.
(iii)	Numbers of occupantes in the family. It help to identify the size of the rooms.
(iv)	Availibility of materials. - It help to the work to finish easily because the materials are easily found.
(v)	Economy. - It help a client to know if he/she can complete his/her building or not.
(vi)	Climatic condition. - It help to identify size and number of opening.

Extract 8.1: A sample of correct responses to Question 8

Extract 8.1 shows a sample of responses from one of the candidates who correctly identified the types of essential information they would need from the client during the planning of the house.

However, 32.01 per cent of the candidates scored low marks from (0 to 1.5). The analysis shows that the majority of the candidates who scored lower marks misinterpreted the requirements of the question. For example, one of the candidates wrote 'foundation plan, roof plan, floor plan, elevation plan, section plan, and window and door plan'. This is a

set for the building working drawings, not the essential information needed from the client during the planning of the house. The responses given by the candidates in this category indicate that they lacked practical knowledge and skills in the development of residential house floor plans. This is revealed by a response from one of the candidates, as shown in Extract 8.2.

Q8.	→ The location of the building
	→ Which type of bond should be used
	→ The schedule of material
	→ The drainage section plan
	→ The water table
	→ The type of soil
	→ Building plot
	→ Window plan

Extract 8.2: A sample of incorrect responses to Question 8

Extract 8.2 shows a sample of responses from one of the candidates who failed to identify the information needed from the client during the planning of the house.

2.2.8 Question 9: Drainage System

The candidates were required to draw the graphical symbols that would represent the given sanitary fixture when preparing a working drawing of a residential building floor plan; (a) Western style water closet, (b) rectangular bath tab, (c) wall-hung urinal, and (d) kitchen sink double drainage board. The question intended to test the candidates' ability to draw graphic symbol of a sanitary fixture.

The question was attempted by 328 (100%) candidates, where by 201 (61.28%) scored from 0 to 1.5 marks of whom 105 (32%) scored 0 mark. Further analysis of the data indicates that 102 (31.10%) candidates scored from 2 to 3.5 marks, while 25 (7.62%) candidates scored from 4 to 6 marks. Figure 10 presents the performance of the candidates in this question.

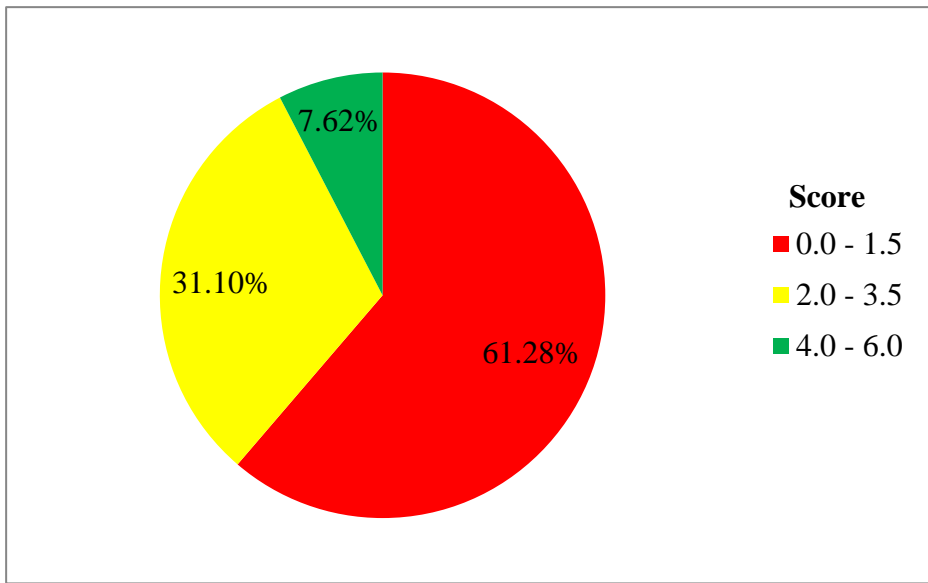
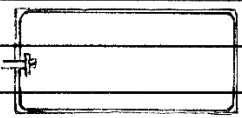
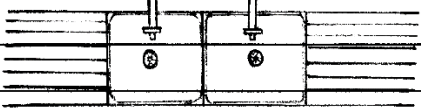

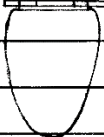

Figure 10: *The Candidates' Performance in Question 9*

The general performance of the candidates was average as 38.72 percent of the candidates scored average and above marks as illustrated in Figure 10. Candidates who had an average and above average scores were able to draw correctly more than two of the graphical symbols, that would represent the given sanitary fixtures when preparing a working drawing of a residential building floor plan. Candidates who managed to draw this item were conversant with the conversion symbols of the sanitary fixtures as presented in Extract 9.1.

09.	Drawing graphical symbols.
	(b) Rectangular bath tub
	
	(d) Kitchen sink with double drainage boards
	
	(c) Wall hung urinal
	
	(a) Western style water closet
	

Extract 9.1: A sample of correct responses to Question 9

Extract 9.1 is a sample of responses from one of the candidates who correctly drew the graphical symbols for the given sanitary fixture items: (a) one-way 13 western style water closet; (b) rectangular bath tub; (c) wall-hung urinal; and (d) kitchen sink with double drainage board.

Further analysis shows that candidates who performed poorly in this question failed to draw the required sanitary symbols. The complete failure is an indicator that the candidates were completely unaware of the concept of sanitary fixtures and associated symbols. Extract 9.2

shows a sample of the incorrect responses from candidates in this category.

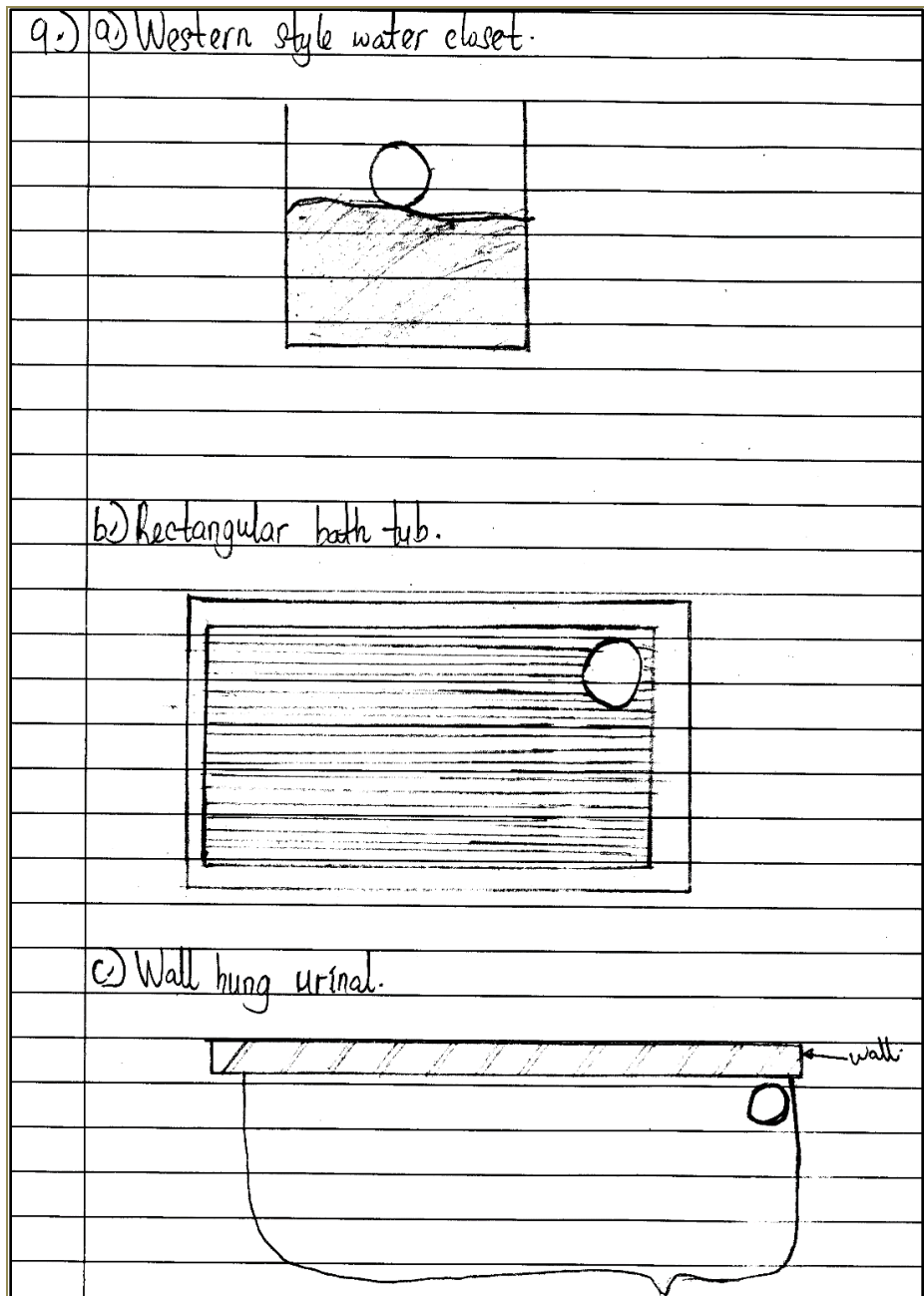

Extract 9.2: A sample of incorrect responses to Question 9

Extract 9.2 shows a sample of responses from a candidate who failed to draw the correct symbols of the sanitary fixtures of the items asked.

2.2.9 Question 10: Doors

This question had parts (a) and (b). This question intended to assess the candidates' ability to design different types of building doors. Candidates were required to explain the four ways in which an office-building door can be designed to close an opening in part (a). In part (b), candidates were tested to explain situation under which the given types of doors can be used (i) Ledged and battened doors, and (ii) Framed battened and braced doors.

The analysis shows that 328 (100%) candidates attempted the question of whom, 255 (77.80%) candidates scored from 0 to 1.5 marks. The candidates who scored from 2 to 3.5 marks were 48 (14.60%), whereas 25 (7.60%) candidates scored from 4 to 6 marks. Figure 11 shows the performance of the candidates in this question.

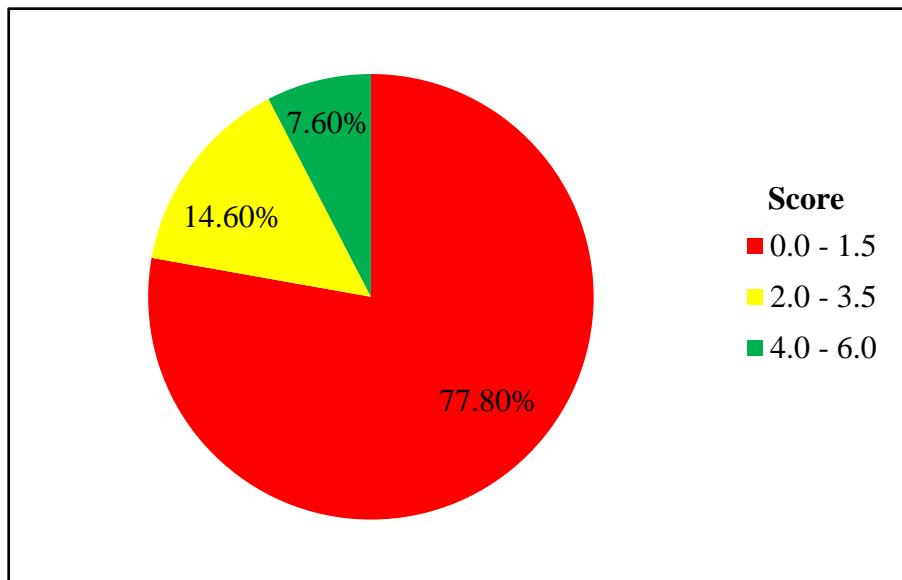

Figure 11: *The Candidates' Performance in Question 10*

The general performance of candidates in this question was poor as depicted in Figure 11. The majority of the candidates who scored low

marks could not clearly explain ways in which an office building door can be designed to close an opening in part (a) of the question. In part (b), the majority of the candidates failed to identify a situation where ledge and battened doors and framed battened and braced doors can be used. Candidates who scored 0 failed to attempt both parts of the question. In part (a), the candidates neither mentioned types of doors or the factors affecting the choice of an office-building door. The failure of the candidates in this question is attributed to the irrelevant interpretation of the question and insufficient knowledge of doors. Extract 10.1 illustrates a sample of incorrect responses presented by a candidate who failed.

10	a) i) Ledge and battened door
	ii) Framed, battened and braced door
	iii) Panned door
	iv) Glazed door
	b) i) In an area with no strong wind
	ii) In an area with strong wind

Extract 10.1: A sample of incorrect responses to Question 10

Extract 10.1 shows a sample of responses from one of the candidates who wrongly interpreted the question and failed to mention the types of door suitable for an office building.

Furthermore, some candidates scored from 2 to 6 marks in part (a) because they perfectly described how an office building door could be designed to close an opening. In part (b), the candidates partially identified a situation where the ledge and battened doors and framed battened and braced doors can be used. The correct responses in part (b) were: (i) *Ledge and battened doors are used for narrow openings in temporary houses where appearance is not the main consideration.* (ii) *Framed, battened and braced doors are used as external doors in residential buildings where strength and not appearance is the main*

consideration. Extract 10.2 is a sample of the correct responses from a candidate in this category.

10.	Ways in which an office building door can be designed to close an opening:
	i. Revolving way
	ii. Sliding way
	iii. Rolling way
	iv. Folding way
(b)	i. Ledged and battened doors are used for small door openings for example in toilet and bathroom.
	ii. Framed, battened and braced doors are used for internal door openings.

Extract 10.2: A sample of correct responses to Question 10

Extract 10.2 is a sample of responses from one of the candidates who in part (a) was able to mention ways in which an office building door can be designed to close an opening. He/she could also partially explain the situation under which a ledged and battened door and framed battened and braced doors can be used in part (b)(i) and (b)(ii).

2.2.10 Question 11: Drainage System

The question tested candidates' knowledge on manhole. The candidates were required to draw a shallow manhole showing (a) a half channel, (b) a drainage chute, (c) benching and (d) drainage pipe.

The analysis shows that 328 (100%) candidates attempted the question. The majority of these, 192 (58.54%), scored between 0 and 1.5 marks. The candidates who scored from 2 to 3.5 marks were 109 (33.23%), while 27 (8.23%) candidates scored from 4 to 6 marks. Figure 12 summarizes the candidates' performance in this question.

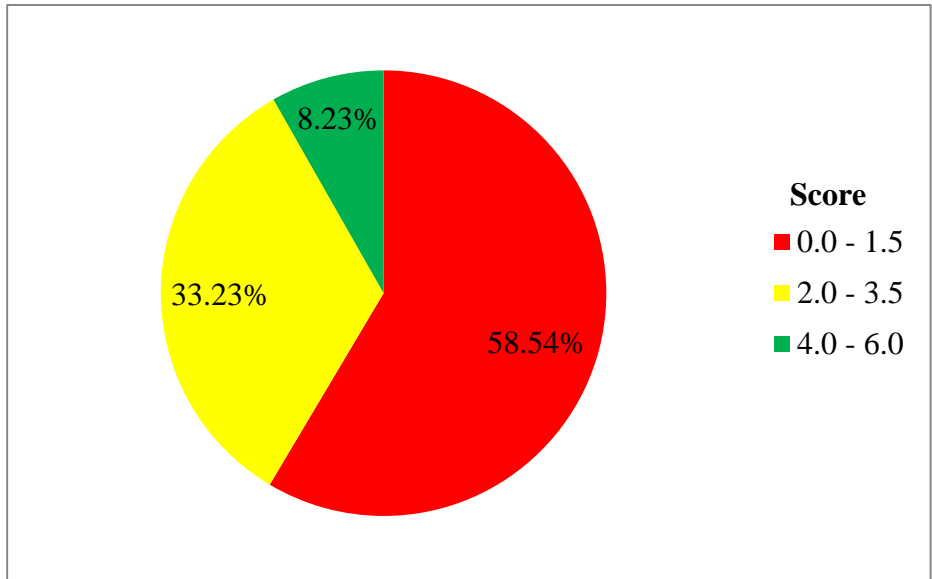
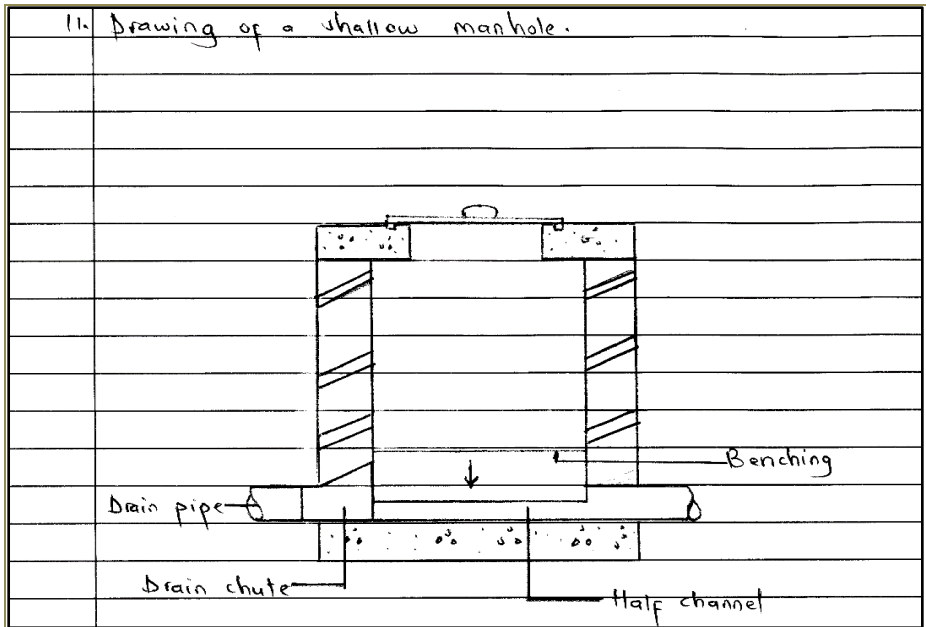

Figure 12: *The Candidates' Performance in Question 11*

The general performance of candidates in this question was average, as Figure 12 illustrates. The majority of the candidates (41.46%) who scored high marks (from 2 to 6) managed to draw a shallow manhole, and labeled all the required parts. Candidates who scored average marks failed to locate the correct position of the half channel and drain chute. They also failed to draw conversional symbols for some materials, especially concrete and walling materials. Extract 11.1 shows a sample of the correct responses provided by a candidate.



Extract 11.1: A sample of correct responses to Question 11

Conversely, candidates who scored low marks (from 0 to 2) were not able to draw the section of a manhole as the question demanded. The majority of the candidates wrongly drew a section or plan of an inspection chamber or a septic tank. They also failed to locate some parts of the manhole. The factors that contributed to the failure of the candidates in this question include a low understanding of the subject matter, a wrong interpretation of the question and poor drawing skills. Extract 11.2 shows a sample of responses by candidates who failed to respond to the question correctly.

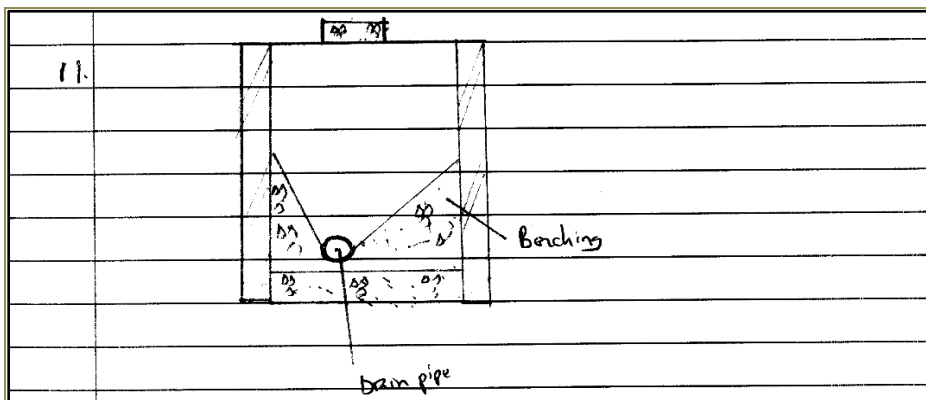

Extract 11.2: A sample of incorrect responses to Question 11

Extract 11.2 is a sample of responses from a candidate who poorly drew an inspection chamber with the wrong labeling of a drainpipe and benching.

2.3 SECTION C: STRUCTURED QUESTIONS

This section consisted of two questions, and candidates were required to attempt only one question. Each question carried thirty (30) marks. The score ranges used for grading the performance of candidates in this section are indicated in Table 2.

Table 2: Score Ranges for Grading Candidates' Performance in Question 12 and 13

Scores Range	General Performance
0 – 8.5	Weak
9 - 19	Average
19.5 - 30	Good

2.3.1 Question 12: Doors

This question had two parts: (a) and (b). In part (a), the candidates were tested on practical application of knowledge on flush doors. They were supposed to recall the design and draw the flush doors showing a ventilation hole in the core rails, plywood skin and lock block. In part (b), candidates were expected to draw the elevation, horizontal section, and vertical section lines through a double leaf panel door using the provided design information. The candidates were tested on five crucial items including, the proper use of architectural scale, and quality of lines, labeling, dimensioning and usage of data to produce a drawing of a panel door. The question was as follows:

- (a) *Draw a skeleton core flush door showing a ventilation hole in a core rails, plywood skin and a lock block.*
- (b) *You are given suggested dimensions for a double leaf shutter having panels in each leaf as follows:*
 - (i) *The size of door opening is 1200 mm x 2100 mm,*
 - (ii) *The size of the timber member for a door frame is 100 mm x 50 mm,*

- (iii) *The size of the timber member for top and intermediate rail is 125 mm x 40 mm,*
 - (iv) *The size of the timber member for bottom rail is 200 mm x 40 mm,*
 - (v) *The thickness of the door shutter is 40 mm,*
 - (vi) *The thickness of the panel member is 25 mm,*
 - (vii) *The size of timber member for styles is 100 mm x 40 mm,*
- Draw a panel door to a scale of 1:10 showing a front elevation, horizontal sectional and vertical sectional through the panels.*

A total of 77 (23.5%) of all the candidates attempted the question, of whom 59 (76.62%) candidates scored from 0 to 8.5 marks. The candidates who scored from 9 to 19 marks were 17 (22.08%), whereas only 2 (1.30%) candidates scored from 19.5 to 30 marks. The performance of the candidates in this question is summarized in Figure 13.

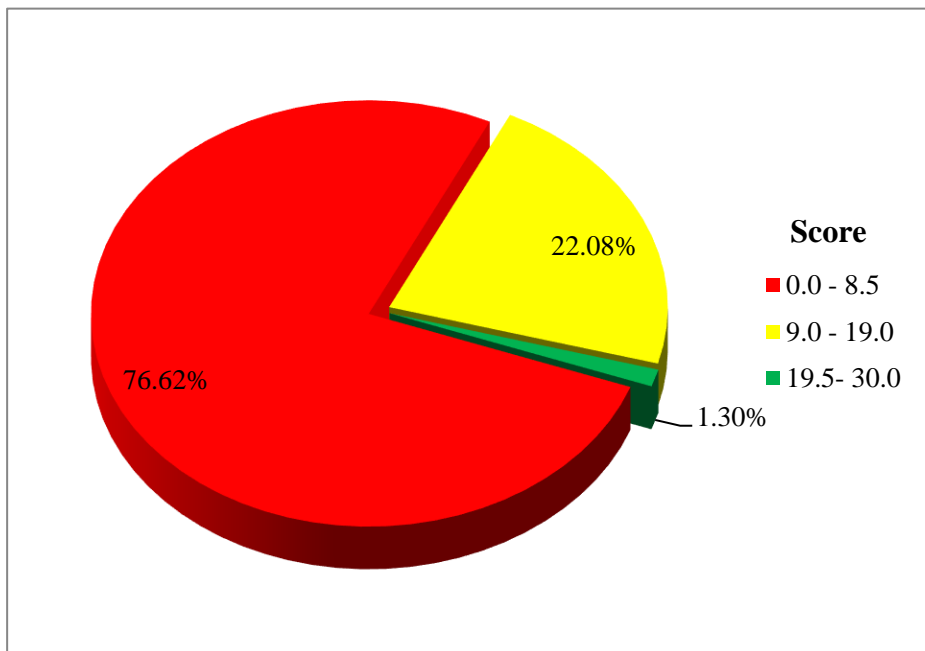
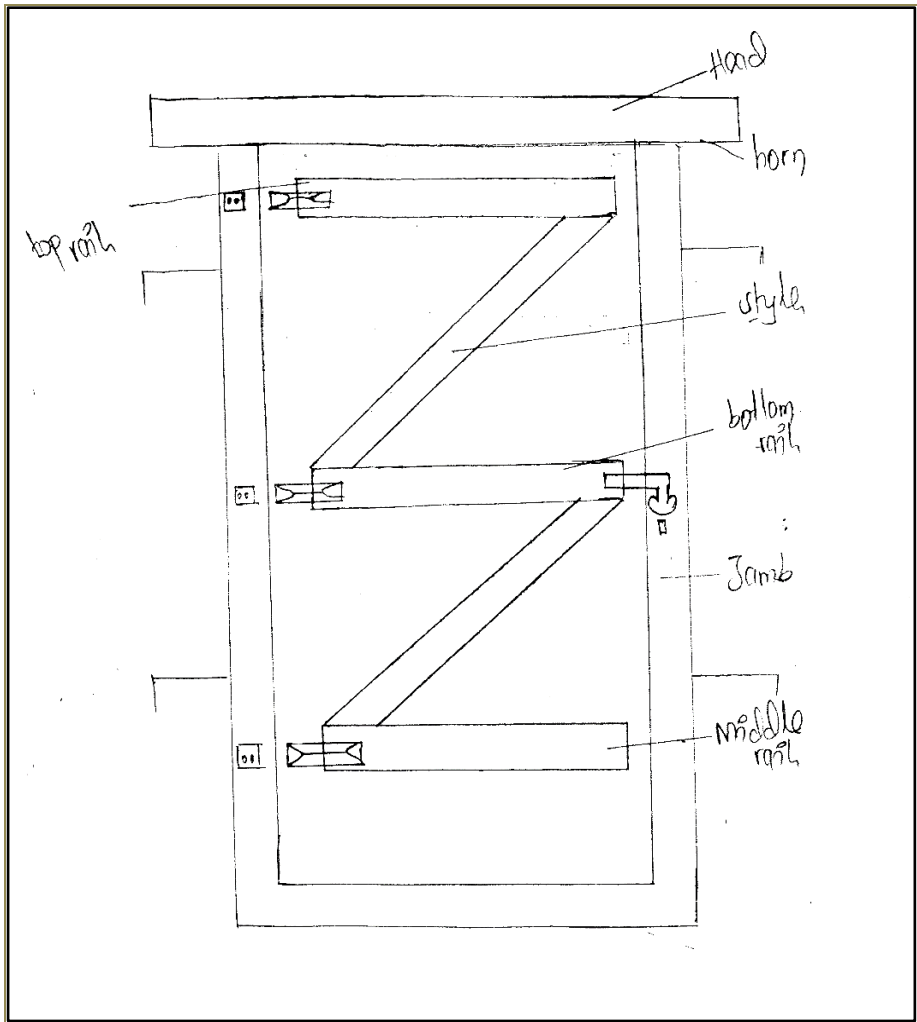

Figure 13: *The Candidates' Performance in Question 12*

The general performance of candidates in this question was poor, as depicted in Figure 13. Majority of the candidates, 59(76.62%) scored low marks because they could not clearly draw the flash and the panel

door. They failed to indicate the ventilation hole, plywood skin and the lock block of the flash door as required in part (a) of the question. In part (b), the majority of the candidates failed to draw the elevation of the door with the required number of panels. They also failed to draw the horizontal and vertical sections through the panel. The candidates who scored 0 failed in both parts of the question. Such candidates drew match-boarded doors or the panel door with two or four panels and not three as asked in the question. Their failure in this question is an indicator of the wrong interpretation of the question, poor drawing skills and the inadequate practical knowledge of doors. Extract 12.1 illustrates a sample of the incorrect responses presented by a candidate who failed the question.



Extract 12.1: A sample of incorrect responses to Question 12

Extract 12.1 shows a response from a candidate who wrongly interpreted the question and drew a match-boarded door in part (b) of the question.

Furthermore, candidates who scored from 9 to 18 marks were able to draw the skeleton flush door but failed to show one of the parts asked in part (a). They also managed to draw the panel door with one of the sections. Moreover, the candidates who scored 19-30 marks perfectly managed to draw the skeleton flush door showing the ventilation hole core rails, plywood skin and lock block in part (a) of the question. They also drew the elevation and sections of the panel door. The variation in

their marks depended on the proper use of architectural scale, neatness, the quality of lines, labeling, dimensioning and the usage of data to produce the anticipated drawing. Extract 12.2 is a sample of the correct responses from a candidate in this category.

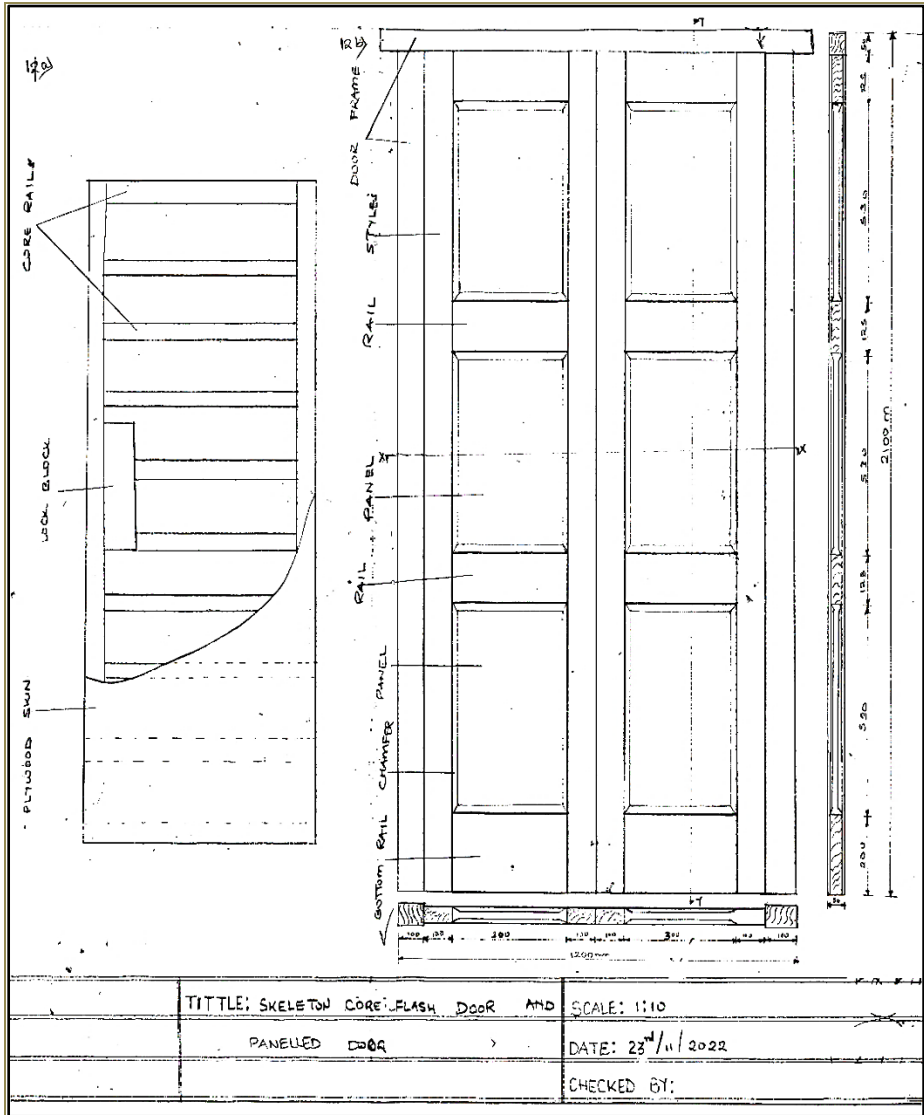

Extract 12.2: A sample of correct responses to Question 12

Extract 12.2 shows a response from a candidate who drew the flush door elevation showing the ventilation hole core rails, plywood skin and

lock block in part (a). He/she also drew the elevation and section panel door in part (b).

2.3.2 Question 13: Roofs

This question had three parts (a), (b) and (c). In part (a), the candidates were supposed to recall the pictorial view of a hipped roof and show the following parts: verge, ridge, common rafter, valley rafter, jack rafter and hip rafter. In part (b) and (c) candidates were tested on the proper use of architectural scale, neatness, quality of lines, labelling, dimensioning and usage of data to produce the sectional drawing of a closed couple roof. The question was as follows:

- (a) *Draw a pictorial drawing of the hipped roof showing the following parts of the roof*
- | | | |
|---------------------------|------------------------|----------------------------|
| (i) <i>Verge</i> | (ii) <i>Ridge</i> | (iii) <i>Common rafter</i> |
| (iv) <i>Valley rafter</i> | (v) <i>Jack rafter</i> | (vi) <i>Hip rafter</i> |
- (b) *By using a scale of 1:50, draw a section through the close couple roofs with span of 8m and a pitch of 8:12. The roof members should have the following dimensions:*
- (i) *Ridge 125 mm x 25 mm*
 - (ii) *Common rafter, binder, collar, ceiling joist and a wall plate is 100 mm x 50 mm.*
 - (iii) *Purlin 150 mm x 75 mm,*
 - (iv) *The overhang should be 600 mm.*
- (c) *What will be the length of the common rafter measured from your drawing?*

The analysis shows that 251 (76.5%) candidates attempted the question of whom, 69 (27.49%) candidates scored from 0 to 8.5 marks. The candidates who scored from 9 to 19 marks were 149 (59.36%), whereas 33 (13.15%) candidates scored from 19.5 to 30 marks. Figure 14 presents the candidates' performance in this question.

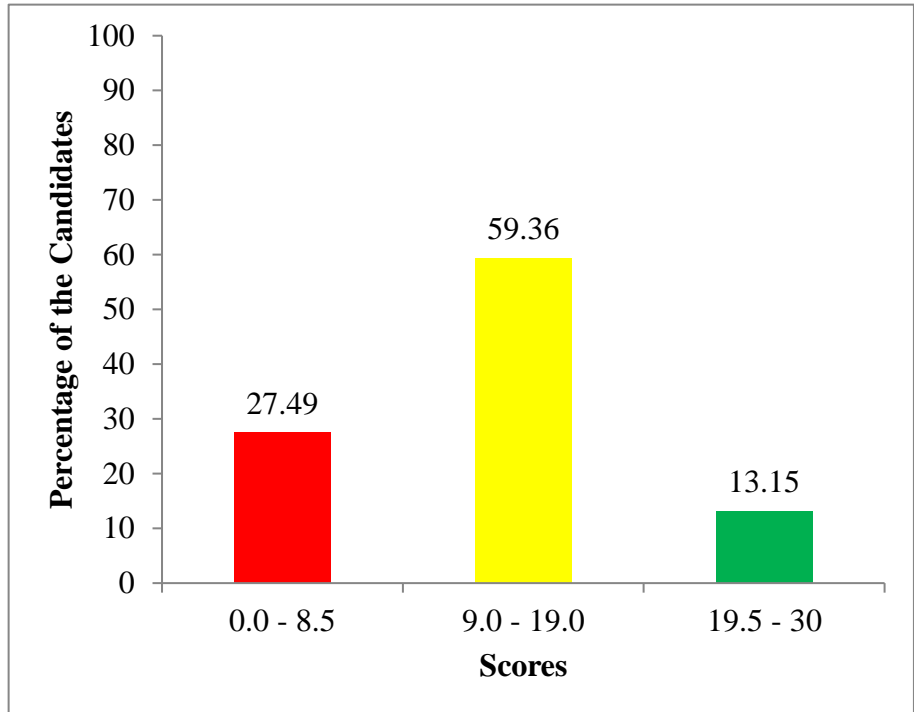
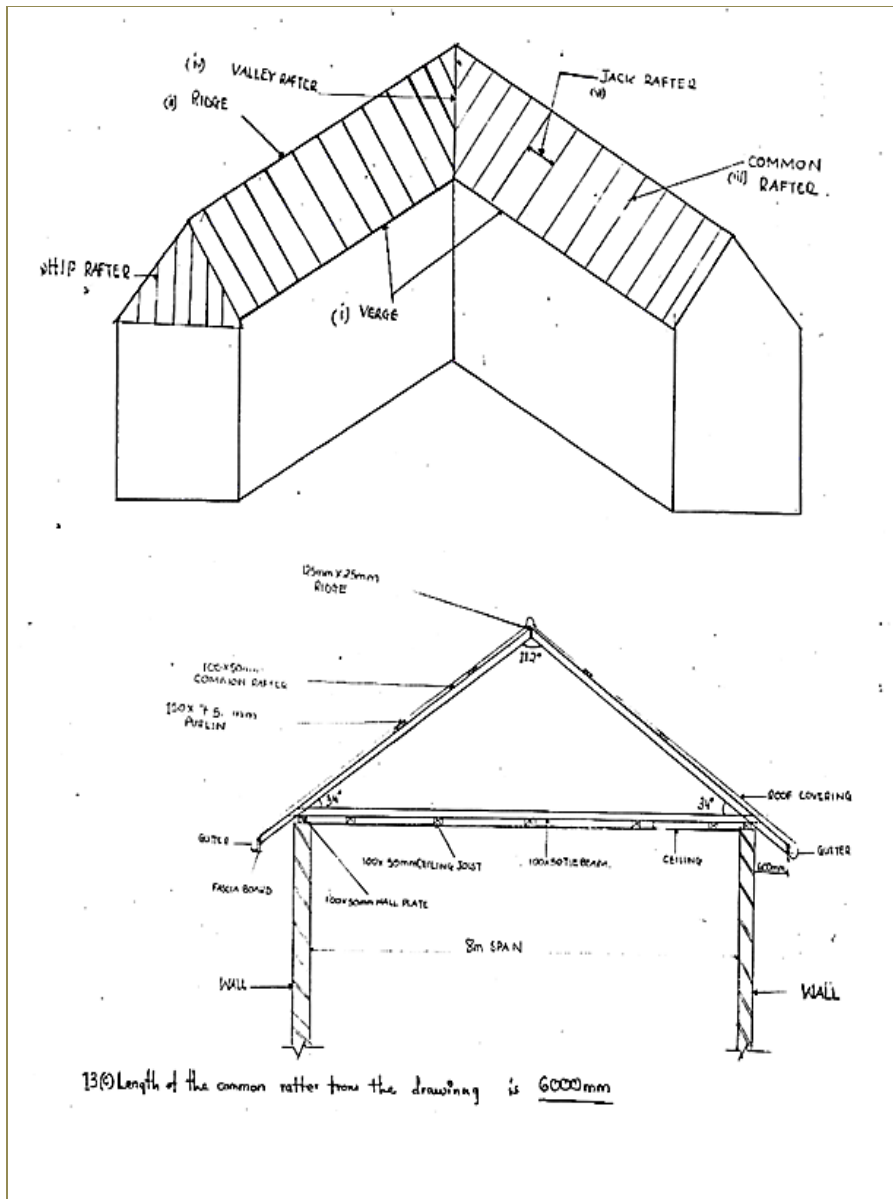

Figure 14: *The Candidates' Performance in Question 13*

Generally, the performance of candidates was good, because 72.51 percent of the candidates scored average and above marks as illustrated in Figure 14. These candidates scored high marks because they had sufficient knowledge and skills in drawing the roof. Their variation in marks depended on the correctness of the presentation of the drawing, dimensioning, the proper title block, neatness, the proper use of scale and the ability to recall procedures for presenting the pictorial and sectional drawing on the standard drawing paper. Extract 13.1 shows a sample of the good responses provided by a candidate.



Extract 13.1: A sample of correct responses to Question 13

Extract 13.1 is a response from one of the candidates who was able to draw a pictorial view of the pitched roof and showed the required parts in (a). He/she managed to draw the required section of the close couple roof and correctly measured the length of the common rafter.

Conversely, candidates who scored lower marks (from 0 to 8.5) failed to draw properly the pictorial view of the pitched roof and a section of

the close couple roof as the question required. The majority of such candidates wrongly drew a pictorial view of the pitched roof, a section and the plan of the roof in part (a). They also failed to draw a close couple roof as asked; instead they drew the king post or queen post roof trusses. They also failed to locate some parts of the roof. There were a number of factors, which contributed to their failure in this question. These factors include poor understanding of the subject matter, wrong interpretation of the question and low practices in drawing skills. Extract 13.2 shows a response by a candidate who was not able to respond to the question correctly.

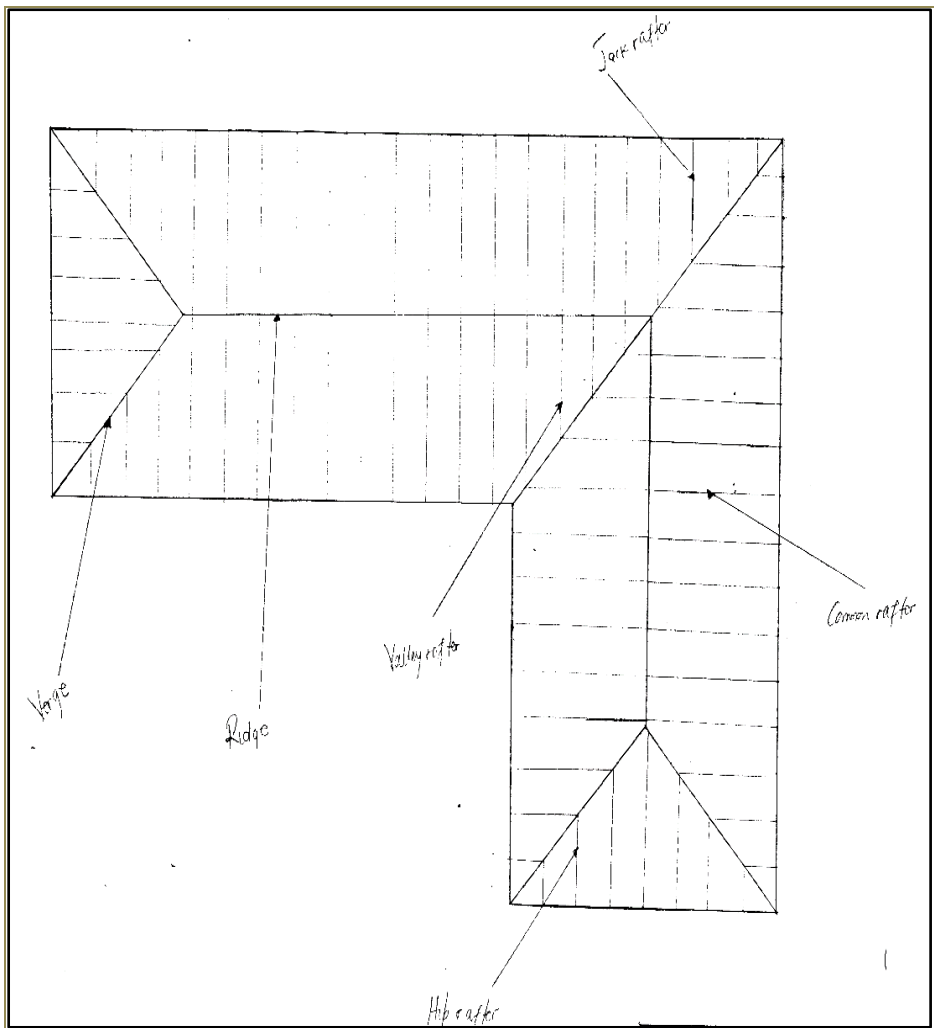

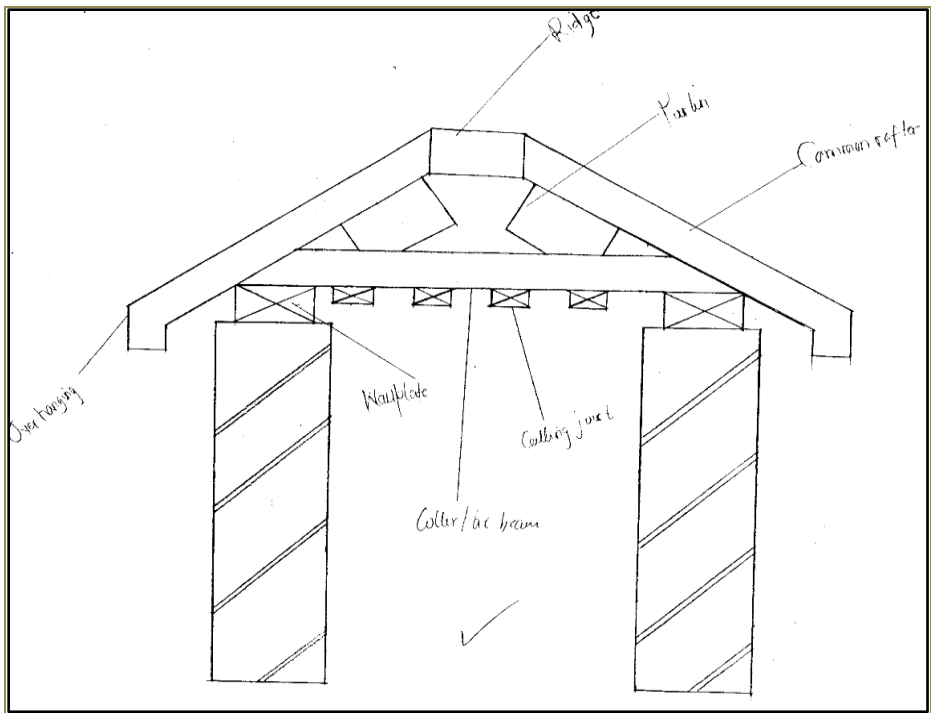

Extract 13.2: A sample of incorrect responses to Question 13

Extract 13.2 is a response from one of the candidates who drew a plan of the pitched roof instead of a pictorial view as asked in part (a). He/she also failed to draw the close roof with the required scale.

3.0 ANALYSIS OF THE CANDIDATES' PERFORMANCE IN EACH TOPIC

A total of 14 topics were examined in Architectural Draughting paper. The analysis shows that the candidates had good performance in seven topics and average performance in four topics. Further analysis shows that the candidates performed poorly in three topics.

The topics that were well performed include those, which were tested in multiple-choice items in question 1. The performance in question 1 was recorded at 91.46%. The topics involved in this question were; Introduction to Building Architecture, Drawing Instruments and Equipment, Architectural Lettering, Architectural Scales, Residential House Planning, Sections, Windows, Fireplaces and Flues, Water Supply and Perspective Drawing. The

performance was also good in the topics of Drawing Instruments and Equipment (76.22%), Stairs and Staircases (82.32%), and Residential House Planning (67.99%). These topics were tested in questions 4, 7 and 8, respectively. The high level of performance in the mentioned topics is attributed to adequate knowledge and the correct interpretation of the question requirements.

The four topics in which the candidates performed averagely were: Roofs (56.16%) which was tested in questions 2 and 13, Architectural Scale (46.34%) tested in question 3 and Drainage System (40.09%) was tested in questions 9 and 11. The average performance in these topics is an indicator that the candidates lacked sufficient knowledge to perform above average in these topics.

The candidates also performed poorly in the topics of Windows (21.04%), Water Supply (15.55%) and Doors (22.79%), which were tested in questions 5, 6, 10 and 12. The analysis shows that the inability of the candidates to identify the requirements of the questions, the misinterpretation of the question requirements and the improper application of knowledge and skills acquired were the causes of the poor performance in these topics.

A summary of the detailed analysis of the candidate's performance in each topic is presented in the Appendix, whereas, green, yellow and red colours represent good, average and weak performances respectively.

4.0 CONCLUSION AND RECOMMENDATIONS

4.1 Conclusion

The analysis of the candidates' performance was done in all questions examined in Architectural Draughting paper, for CSEE 2022. Generally, the performance of candidates in Architectural Draughting paper was average, as only 198 (60.37%) candidates were able to score the pass mark and above.

Candidate's performance in questions 1, 4, 7 and 8 was 'good' while the performance in questions 2, 3, 9, 11 and 13 was "average". The poorly performed questions were 5, 6, 10 and 12.

Poor performance of the candidates might be attributed to the failure of the candidates to interpret the tasks of the questions correctly, partial attempt of the questions, inadequate knowledge of the topics tested, lack of practical skills, poor command of English language and the inadequate site practice.

Drawing equipment and more involvement of students in industrial practical works are required for improving the performance of the prospective candidates' performance. These will help them learn by doing, hence improve the logical and technical understanding of the subject matter.

4.2 Recommendations

4.2.1 Recommendations to Students

Based on the performance observed in this analysis, the following are recommended to prospective candidates:

- (a) To carefully read instructions before answering questions so as to meet the questions demand.
- (b) To read relevant materials and practice in order to widen knowledge, especially in areas where most candidates demonstrated lack of knowledge and practice.

4.2.2 Recommendations to Teachers

- (a) In order to improve candidates' performance, teachers should provide enough exercises and tests for their students before sitting for national examinations.
- (b) Some candidates demonstrated lack of knowledge in aspects that require prior practical skills; it is therefore recommended that such skills be provided to students so that they can integrate theories with practical experience and hence acquire the expected competencies.
- (c) Teachers should guide students to develop technical drawing skills through graded practice. This will help them acquire appropriate drawing skills to draw neatly and label correctly.

Analysis of the Candidates' Performance in Different Topics

S/N	Topic	Question Number	Percentage of the Candidates who Scored 30% and Above	Remarks
1	Introduction to Building Architecture; Drawing Instruments and Equipment; Architectural Lettering; Architectural Scales; Residential House Planning; Sections; Windows; Fireplaces and Flues; Water Supply and Perspective Drawing.	1 (Multiple Choice Items)	91.46	Good
2	Stair and staircase	7	82.32	Good
3	Drawing Instruments and Equipment	4	76.22	Good
4	Residential House Planning	8	67.99	Good
5	Roofs	2,13	55.16	Average
6	Architectural Scales	3	46.34	Average
7	Drainage Systems	9,11	40.09	Average
8	Doors	10,12	22.79	Poor
9	Windows	5	21.04	Poor
10	Water Supply	6	15.55	Poor

